



Critical Design Review

February 12th, 2026



Presentation Overview

- Payload Summary
- Launch Vehicle Final Design
- Recovery System Final Design
- Payload Final Design
- Air Brakes Final Design
- Subscale Flight Results
- Requirement Verification and Status
- Test Plans and Procedures
- Questions



Team Introductions



Elizabeth
Team Lead



Donald
Structures Lead



Aditya
Aerodynamics Lead



Lauren
Recovery Lead



Mason
Payload Software Lead



Emily
Payload Structures Lead



Ben
Payload Electronics
Lead



James
Integration Lead



Aidan
Safety Officer



Payload Summary



ZOMBIE and GrAVE

- Z-axis Orienting Mechatronic Botanical Investigative Extractor
- Ground Activated Vehicle Ejector
- Stored in the Nosecone
- Ejected on landing

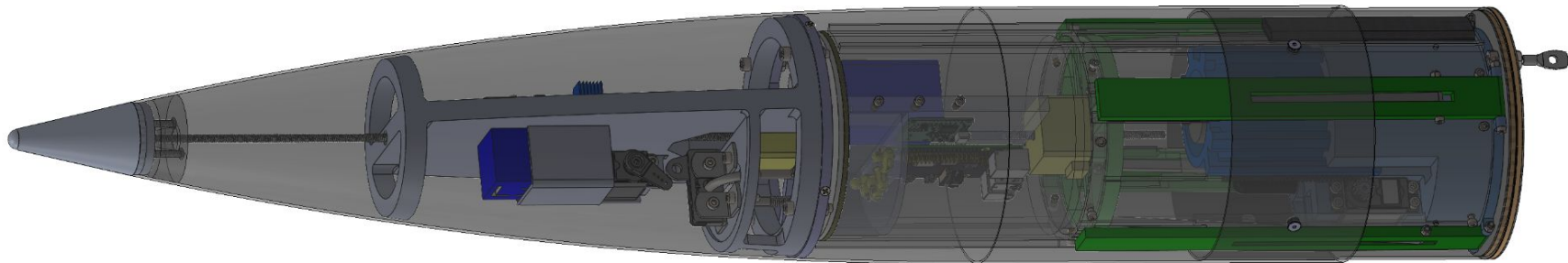



Adjustments required for GrAVE

- Longer Nosecone
- Carbon fiber rails
- In-flight removed bulkhead

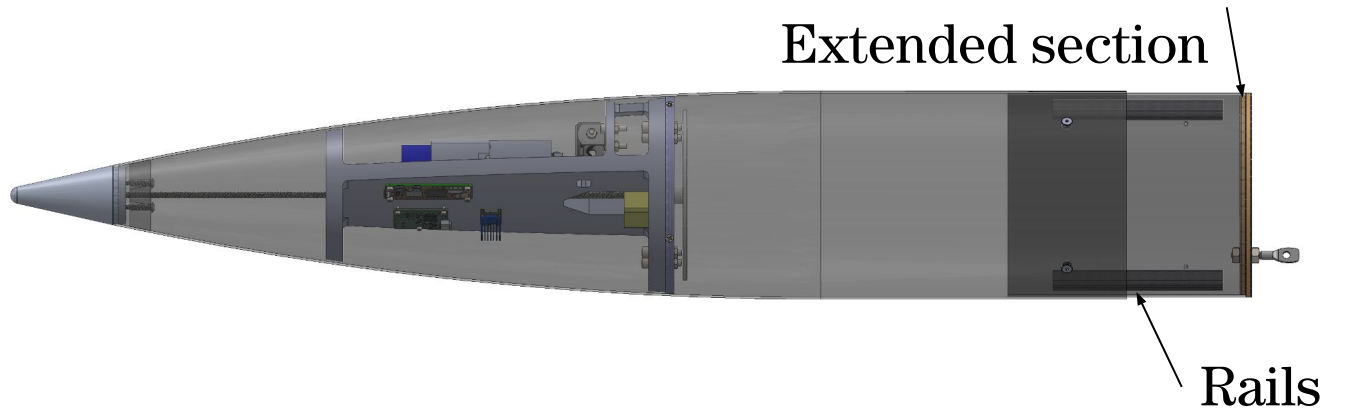

Main Parachute



Nose Cone Bulkhead

M1

M2

Nose Cone



Launch Vehicle Design



Final Launch Vehicle Dimensions

- Overall Length: 110.9 in
- Outer Airframe Diameter: 6.12 in
- Aspect Ratio: 18.2
- Sections: 3 Body Tubes, 3 Couplers, 1 Nosecone

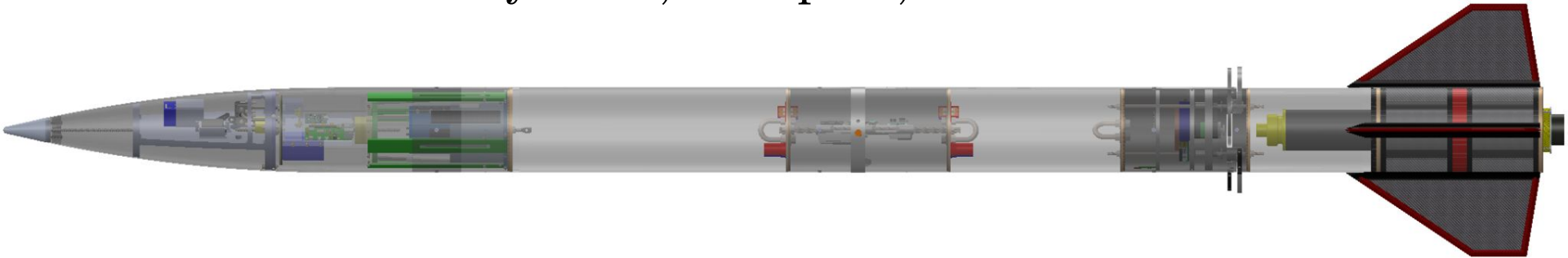



Vehicle Separation Points

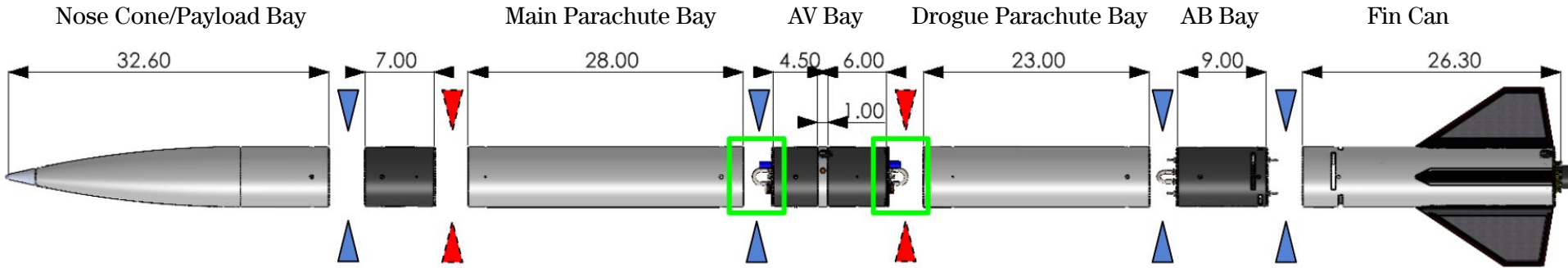

- Dual deployment system
- Main parachute forward of AV Bay
- Drogue parachute aft of AV Bay

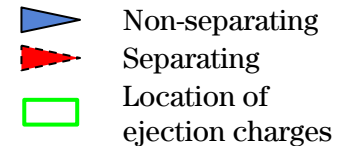



Airframe and Plate Construction

Airframe Tubes

- S2 8.9 oz/yd² Fiberglass
- Roll-wrapped lamination
- Heat-shrink sleeve compaction

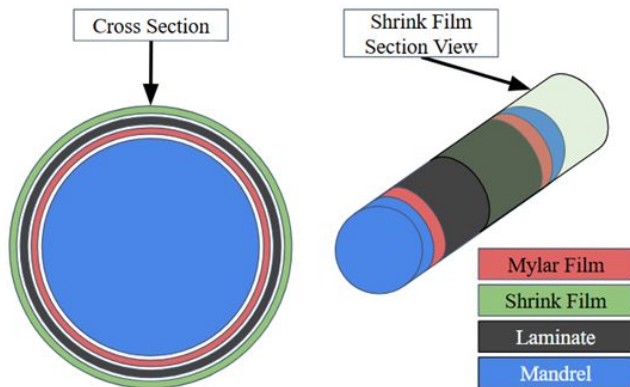

Fins, Bulkheads, and Centering Rings

- Fiberglass or carbon fiber face sheets depending on location
- 1/8 honeycomb Nomex core

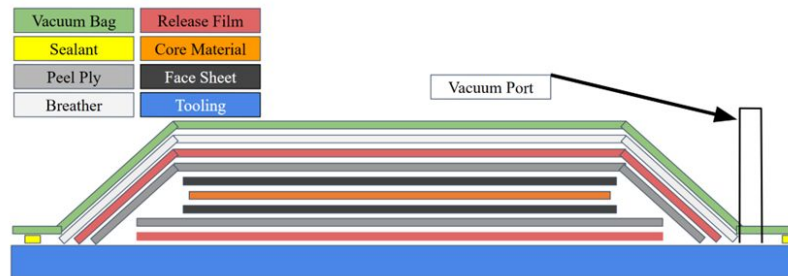



Nosecone

- 4:1 aspect ratio with a fiberglass body and 6061 aluminum tip
- Extended 9 in airframe diameter length
- 7 in coupler with mounts half way

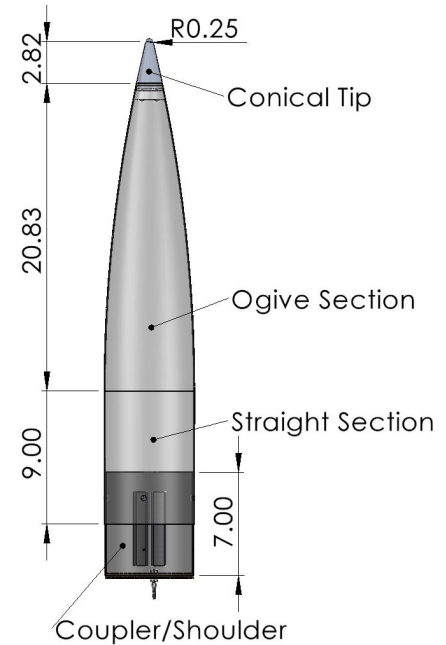
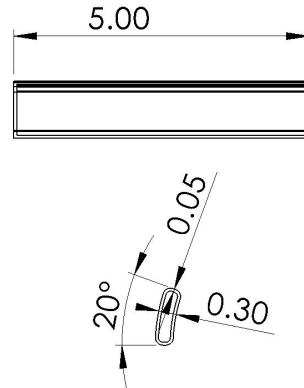



Drogue and Main Parachute Bays

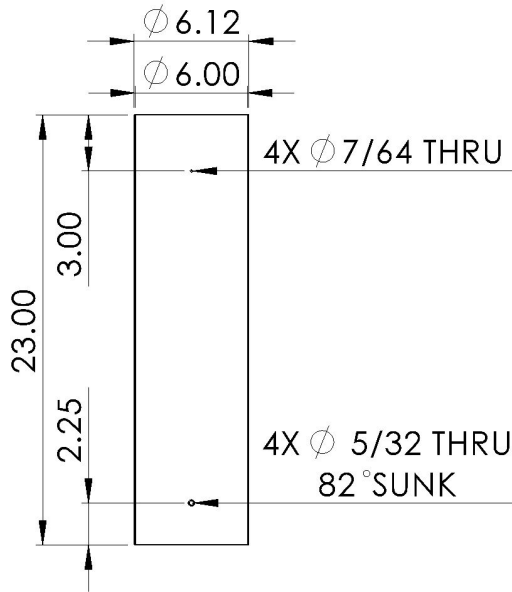

Drogue Parachute Bay

- Nylon shear pins for in-flight separation points
 - 4 x 4-40 screws
- Steel countersunk screws for non-in-flight separations
 - 6-32 press-fit nuts
 - 6-32 82° countersunk screws

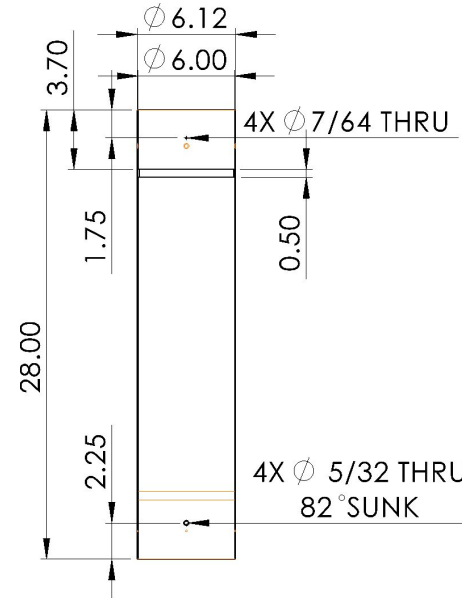

Main Parachute Bay



Avionics Bay

- 11.5 in coupler tubing and 1 in switchband located 6 in from aft
- Stepped bulkheads
- Forward rail button

- 2 x 3/8 in stainless steel u-bolts
- 2 x 1/4 in stainless steel threaded rods for bulkhead retention

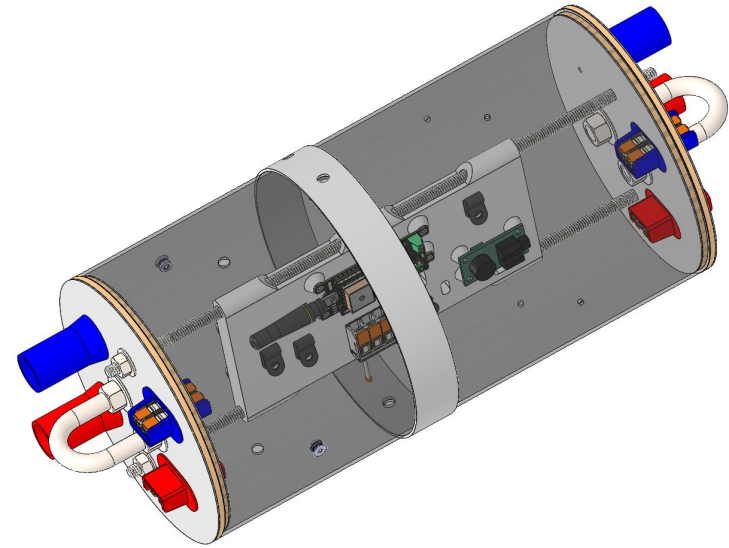



Fin Can

- Centering rings with honeycomb Nomex core and carbon fiber face sheet
- 2.975 in ID thin-wall carbon fiber tube
- Water-jet 6061 aluminum motor retainer
- Aft rail button placement
- 3D printed PLA alignment ring
- Air Brakes slots cut in forward end

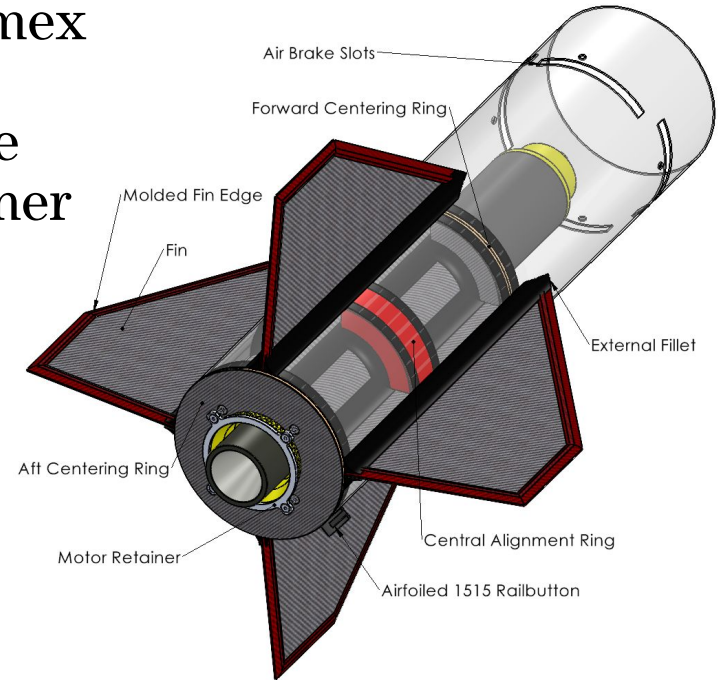



Air Brakes Bay

- 9.0 in coupler tubing with central coupling displacement
- Stepped bulkheads
- 3/8 in stainless steel u-bolt
- 2 x 1/4 in stainless steel threaded rods for bulkhead retention

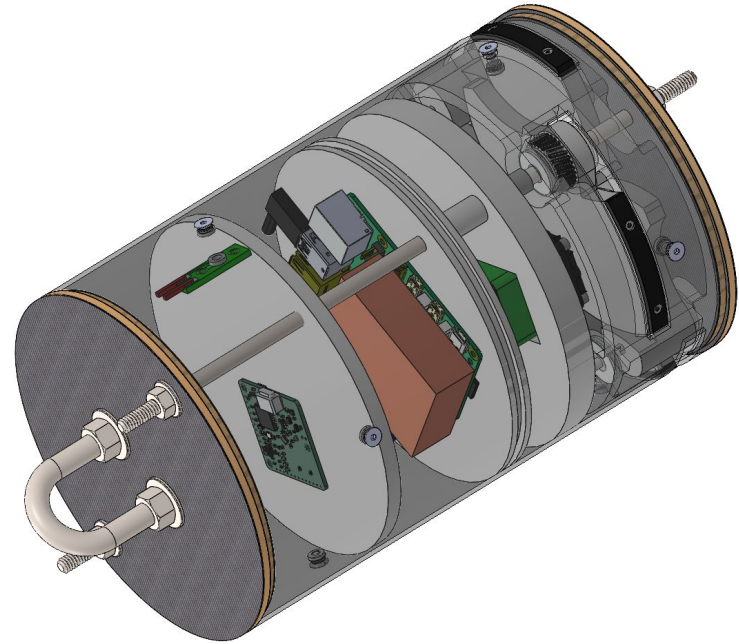



Fins

- Single $\frac{1}{8}$ in honeycomb Nomex core
- 7-ply face sheet laminates
- Molded chopped tow carbon fiber and fiberglass fairing for leading, trailing, and tip edge

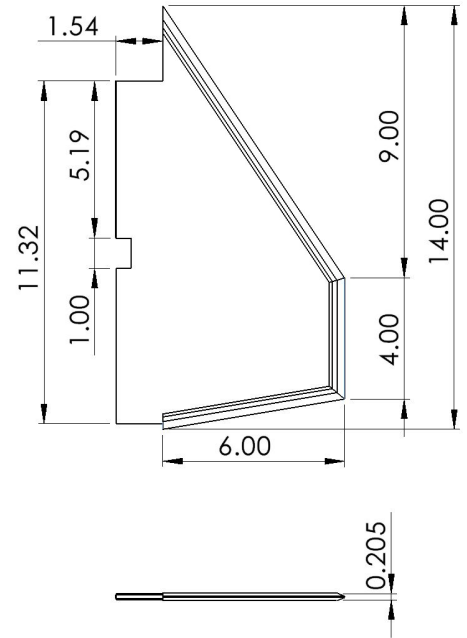



Vehicle Plate Laminates

Component	Layup Sequence				
Avionics & Nosecone Bulkheads	4 x [0/90] FG	Honeycomb Nomex Core	1 x [0/90] FG	Honeycomb Nomex Core	4 x [0/90] FG
Air Brakes Bulkheads	5 x [0/90] CF	Honeycomb Nomex Core	1 x [0/90] CF	Honeycomb Nomex Core	5 x [0/90] CF
Forward and Aft Centering Ring	5 x [0/90] CF	Honeycomb Nomex Core	1 x [0/90] CF	Honeycomb Nomex Core	5 x [0/90] CF
Fins (Symmetric About Honeycomb Nomex)	1 x [-45/+45] Spread CF	1 x [0/90] CF	2 x [-45/+45] CF	1 x [0/90] CF	2 x [-45/+45] CF



Mission Performance



Motor Selection

Flight Profile Comparison between L1390G and L1520T

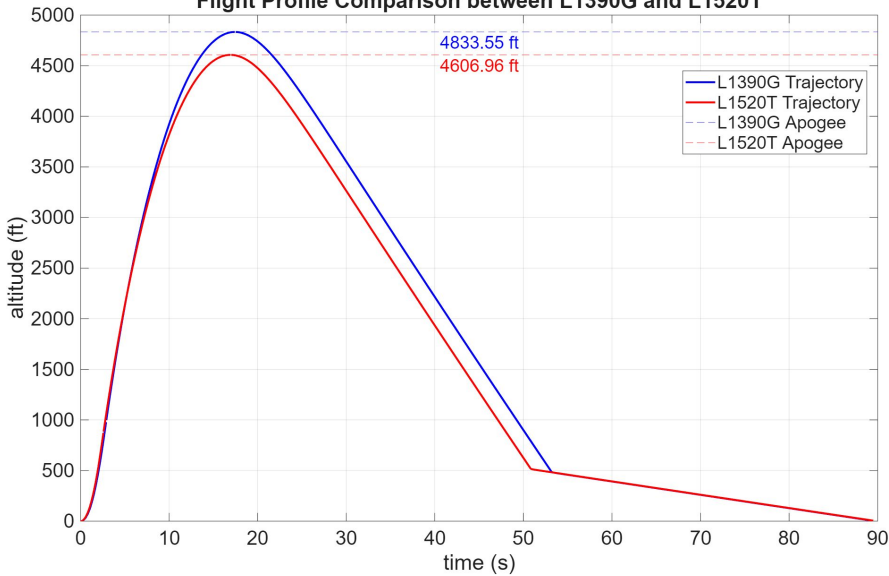

Motor	Primary: L1390G	Secondary: L1520T
Total Impulse	887.77 lbf · s	835.37 lbf · s
Average Thrust	312.48 lbf	352.46 lbf
Burn Time	2.6 s	2.4s
Thrust to Weight Ratio	7.78:1	8.68:1
Rail Exit Velocity	74.8 ft/s	79.8 ft/s



Static Stability Margin

Software	Center of Pressure (in)	Center of Gravity (in)	Stability Margin (Calibers)
OpenRocket	85.24	64.63	3.37
RocketPy	85.08	63.425	3.54
RasAeroII	85.19	64.505	3.40

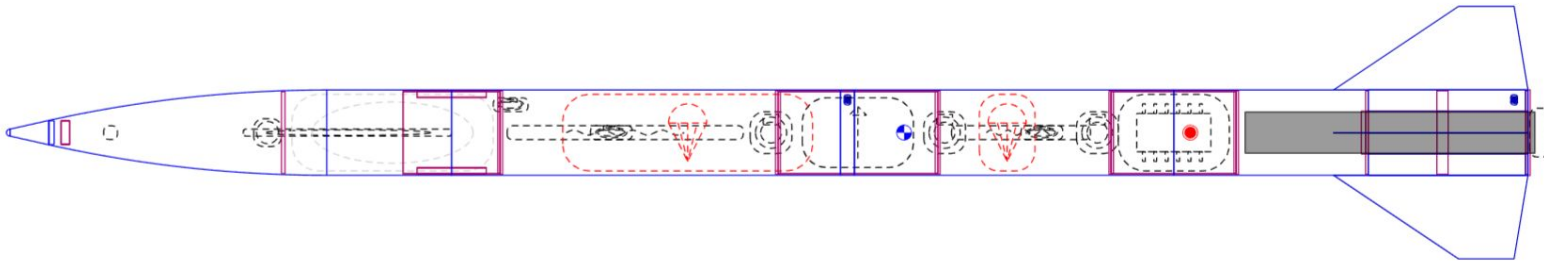



Flight Profile Without Air Brakes

- Apogee: 4833 ft
- Time to Apogee: 17.4 s
- Max Velocity: 626 ft/s
- Max Acceleration: 276 ft/s²
- Velocity off rail: 74.8 ft/s

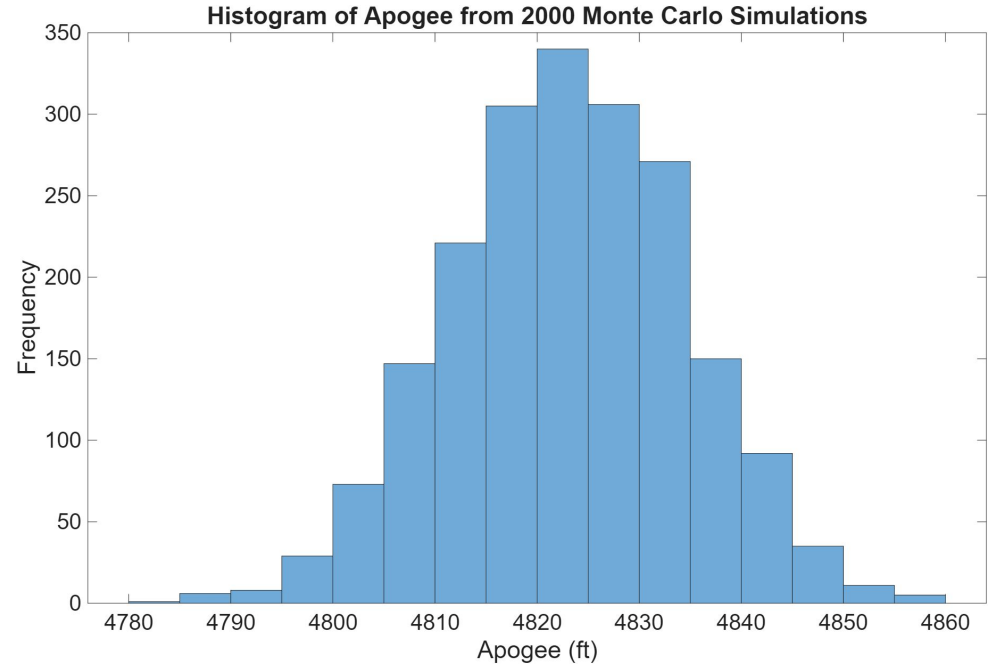
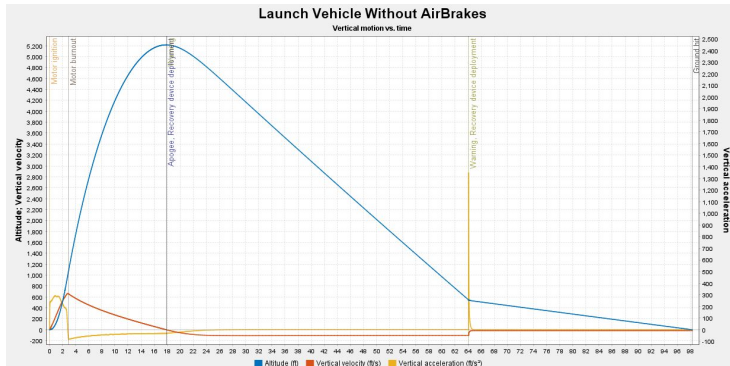



Center of Gravity During Flight

- The Air Brakes Location is 84.5 in
- Static CG is 64.629 in
- Burnout CG is 60.35 in
- All Locations are measured from the tip of the Nosecone

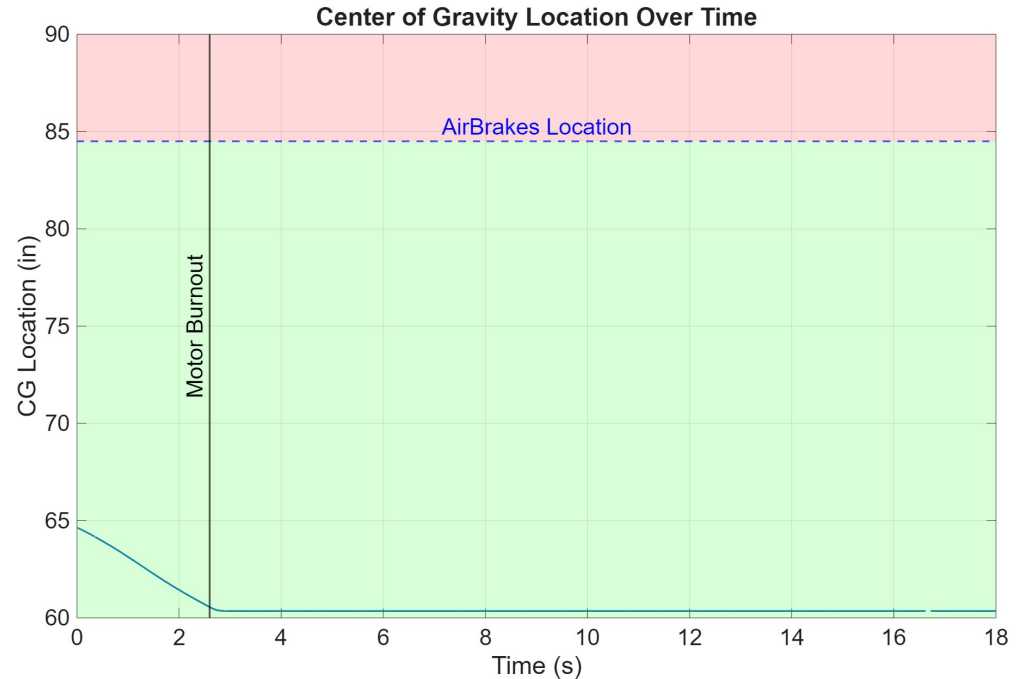



Flight Profile With Air Brakes

- Target Apogee: 4600 ft
- Apogee*: 4564 / 4591 ft
- Time to Apogee: 16.7 s
- Max Velocity: 626 ft/s
- Max Acceleration: 276 ft/s²
- Velocity off rail: 74.4 ft/s

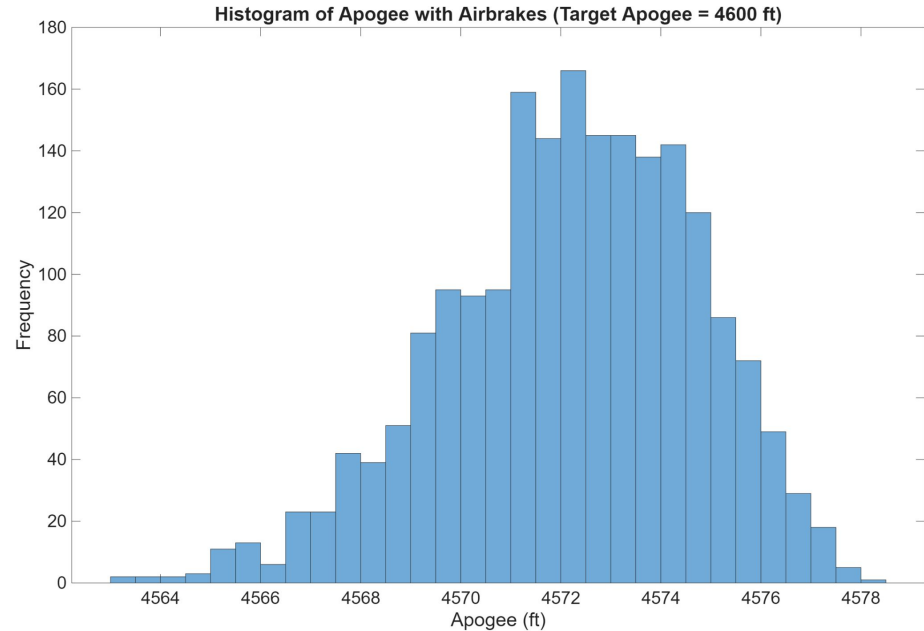
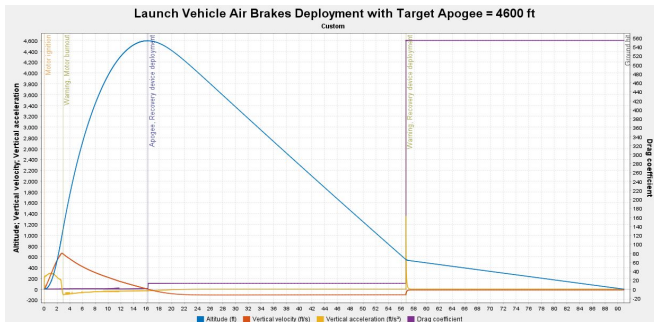

* OpenRocket / RocketPy



Official Target Altitude

- Based on simulations, official target Apogee is 4600 ft.

Wind Speed (mph)	Apogee (ft)	Target Set (ft)
0	4600	4600
5	4600	4625
10	4601	4635
15	4598	4655
20	4603	4675



Recovery System Design



Recovery Overview

Drogue Deployment

- Apogee
- Secondary 1 second after primary

Main Deployment

- 550 ft.
- Secondary at 500 ft.

All sections connected via shock cord with a minimum of 8 ft of separation between sections

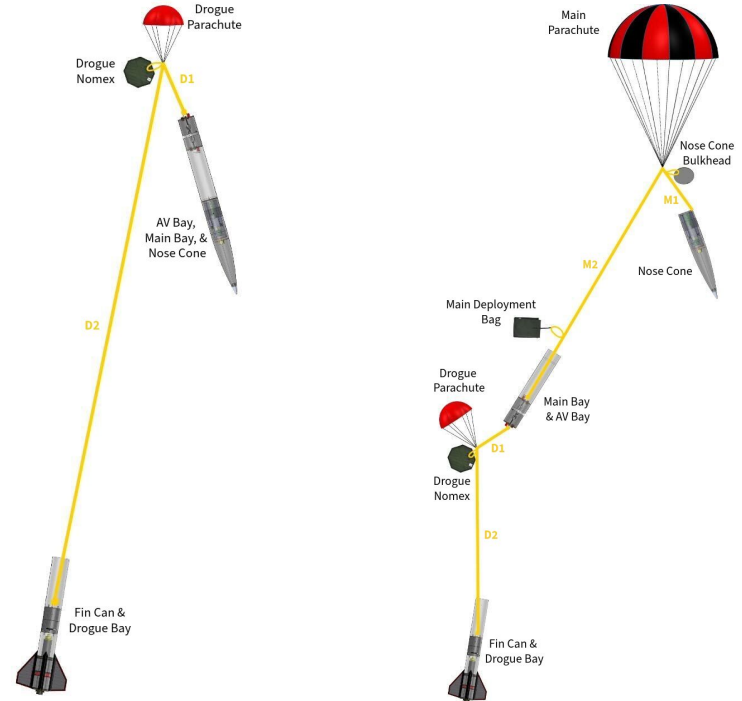



Recovery System CONOPS

Landing:

1

- Primary and secondary altimeters are armed on the launch pad and continuity is verified.
- GPS Transmission confirmed

Drogue Deployment:

2

- Drogue primary charge initiated at apogee.
- Drogue secondary charge initiated 1 sec after apogee.

Main Deployment:

3

- Main primary charge initiated at 550 ft.
- Main secondary charge initiated at 500 ft.

Landing:

4

- Kinetic energy is below 65 ft-lbf.
- Total descent time is below 80 sec.
- Total drift distance is below 2500 ft.

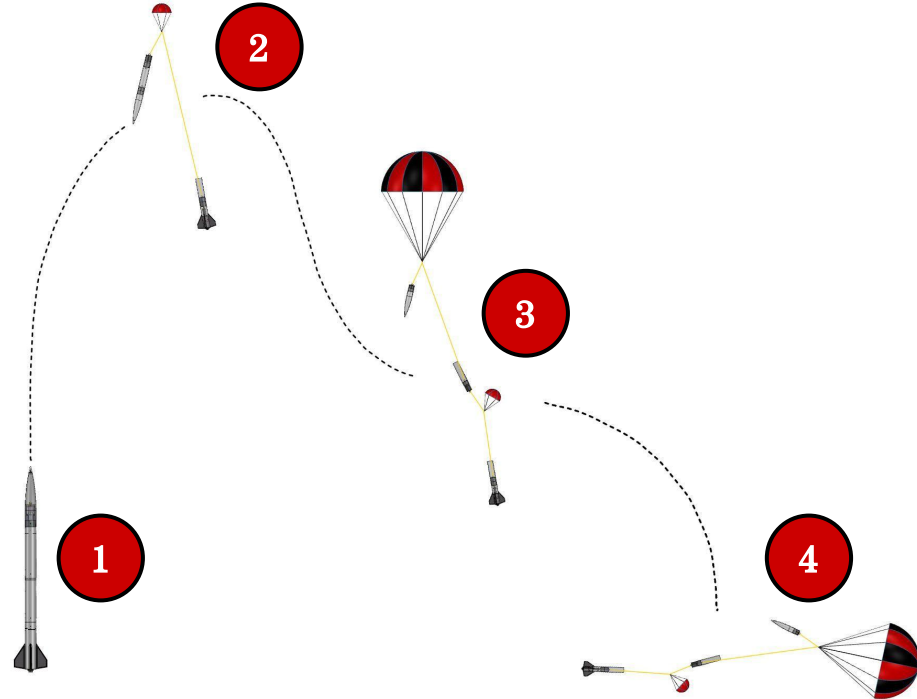



Parachute Selection

Drogue

- 15” custom elliptical
- Protected by Nomex blanket

Main

- Fruity Chutes Iris Ultra 120” Compact
- Protected by Fruity Chutes Deployment Bag





Shock Cord

- 1/2" Kevlar shock cord
- 6000 lbf strength rating

Drogue Configuration	
D1	24 in
D2	202.6 in
Total Length	226.6 in

Main Configuration	
M1	24 in
M2	179.5 in
Total Length	203.5 in

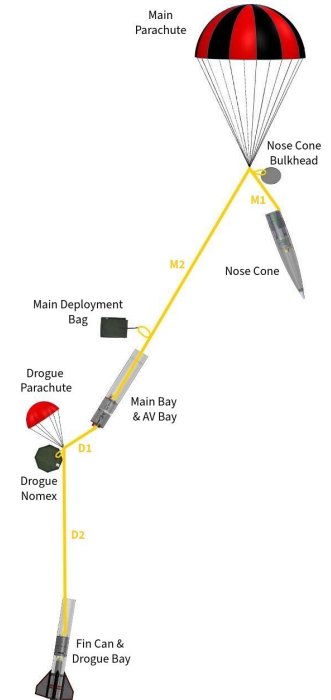
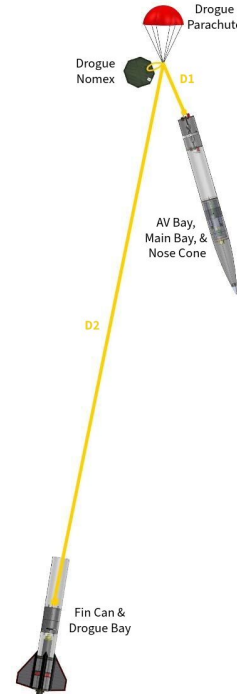



Recovery Attachment

1/8" Kevlar soft links

- 3 passes = 5130 lbf strength rating
- Soft links connect Alpine Butterfly loops on shock cord to U-bolts.

Nosecone attachment

- Knotted and epoxied into carbon fiber tube

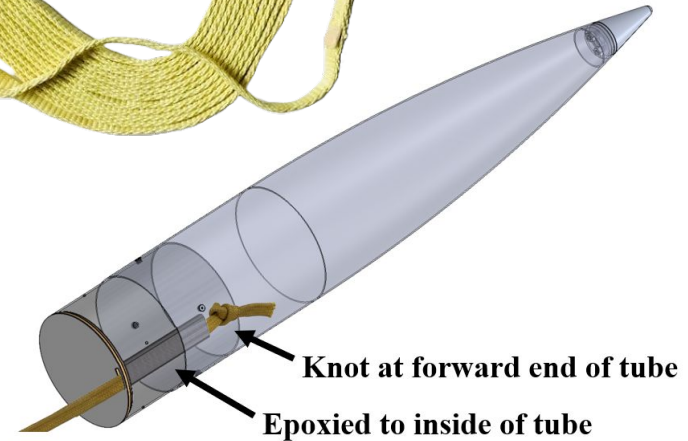



Factor of Safety

$$F_{shock} = \frac{m\Delta v}{t_{infl}}$$

Shock Force = 414 lbf

FOS = 5.31

Component	Strength Rating (lbf)
120 (in) Fruity Chutes Iris Ultra Compact Parachute	2200
4 x 6-32 (in) Steel Screws	2440
3/8 (in) Stainless Steel U-bolt	3500
Fiberglass Bulkhead	3540
2 X 1/4-20 (in) Stainless Steel Threaded Rods	4220
1/8 (in) Kevlar Soft Link	5130
1/2 (in) Kevlar Shock Cord	6000
Epoxied Nosecone Attachment	10000



Avionics

Primary Altimeter: Silicdyne Fluctus

- Initiates drogue at apogee
- Initiates main at 550 ft.
- 7.4V 800mAh LiPo battery

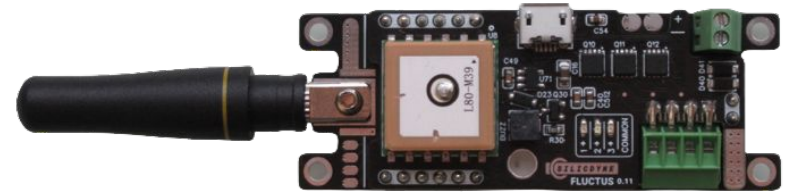

Secondary Altimeter: Altus Metrum EasyMini

- Initiates drogue 1 sec after apogee
- Initiates main at 500 ft.
- 3.7V 500 mAh LiPo battery

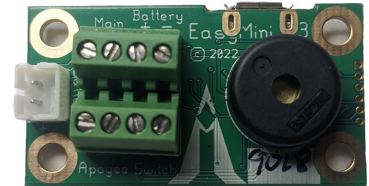

GPS Tracking: Silicdyne Fluctus

- Transmits on a 900 MHz band
- SteadyBlue ground station



Wiring Diagrams

Primary Altimeter

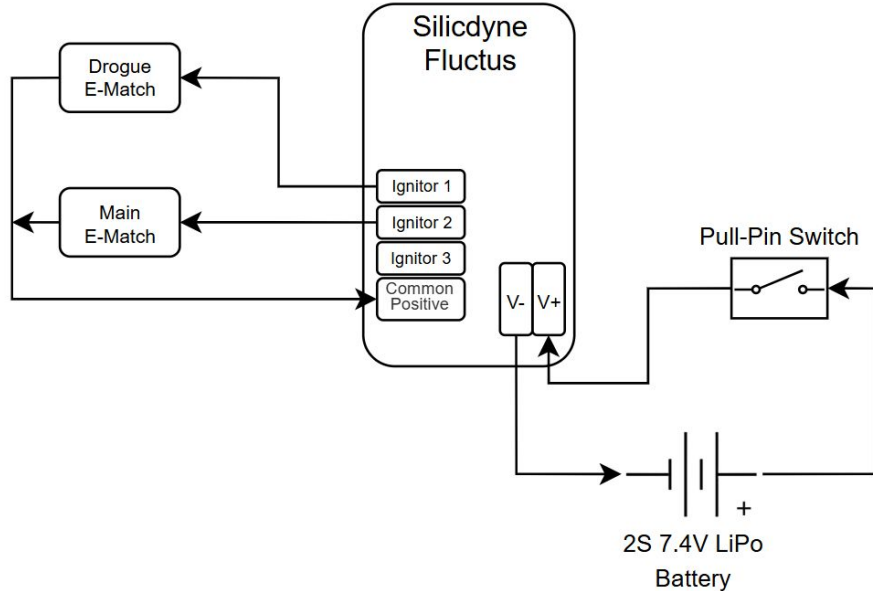

Secondary Altimeter

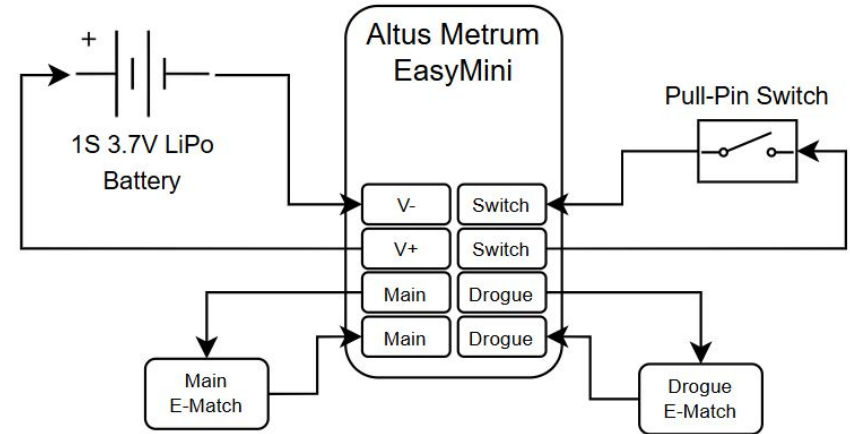



Avionics Sled

- 3D Printed PLA
- All avionics mounted directly to sled
- Built-in slots for batteries, in addition to Velcro
- Wire clamps route igniter wires to in-line WAGO connectors
- Color-coded wires and charge wells

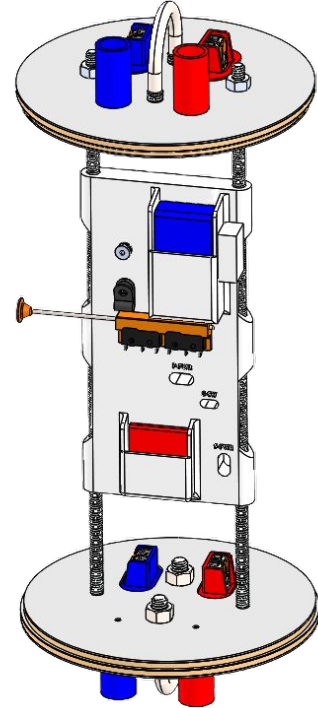
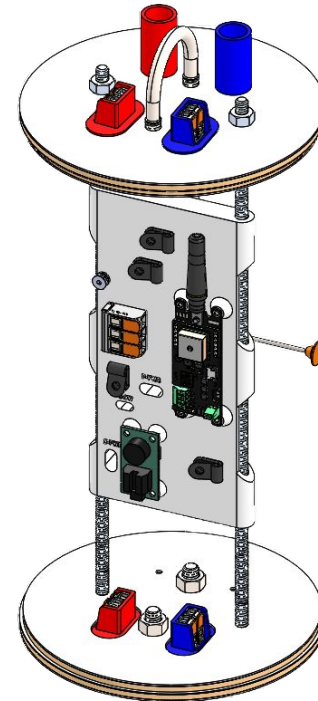



Kinetic Energy

Max kinetic energy at landing = 44.28 ft-lbf

Section	Mass (lbm)	Descent Velocity (fps) under Drogue	Kinetic Energy (ft-lbf) under Drogue	Descent Velocity (fps) under Main	Kinetic Energy (ft-lbf) under Main
Nosecone	10.30	129.66	4542	13.33	28.42
AV Bay + Main Bay	5.26				14.51
Fin Can + Drogue Bay	16.05		4190		44.28



Descent Time and Drift Distance

Assuming:

- Apogee of 4600 ft
- Main parachute deployment at 550 ft
- Total descent time of 72.49 s
- Constant wind

Max drift distance: 2126 ft

Wind Speed (mph)	Drift Distance (ft)
0	0
5	531.6
10	1063
15	1595
20	2126



Ejection Charges

- 4 x 4-40 nylon shear pins
- FOS of 1.5 applied to primary charges
- FOS of 2 applied to secondary charges

Separation Event	Primary Charge Mass	Secondary Charge Mass
Drogue Parachute Deployment	2.92 g	3.89 g
Main Parachute Deployment	2.75 g	3.66 g



Payload Design



Payload Design

- Z-axis Orienting Mechatronic Botanical Investigative Excavator (ZOMBIE)
- Ground Activated Vehicle Ejector (GrAVE)

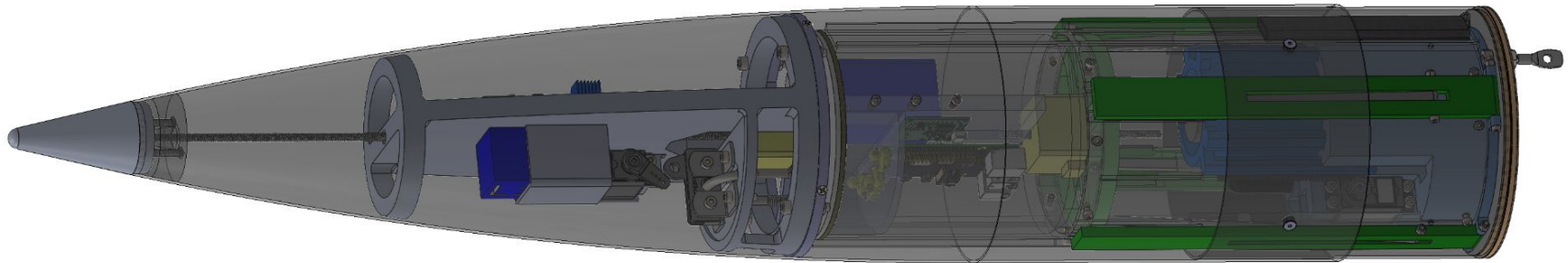



Payload CONOPS

- Launch
 - Secured by rails
- Landing detection
 - Inertial Navigation System
 - State machine code
- GrAVE extension
 - Electronic Latch
 - Pushing mechanism

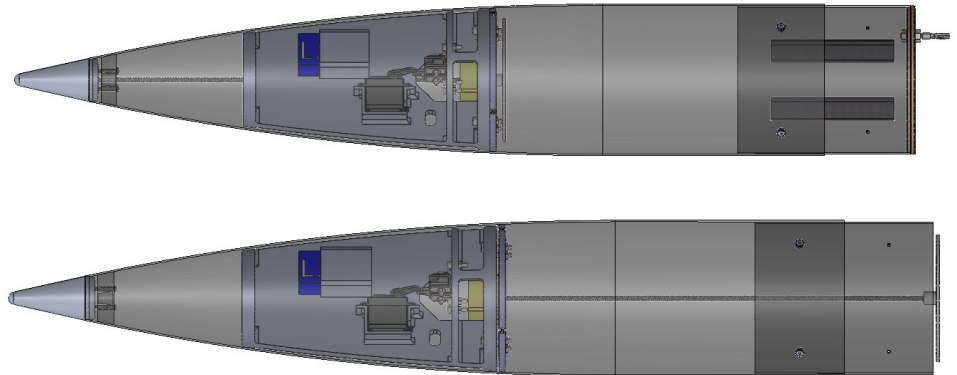



Payload CONOPS cont.

- ZOMBIE activation
 - Legs unhinge
 - Collar deployment
 - Using lead screw
- Orientation checks
 - Use INS
 - Repeat until correct
- Drilling operation
 - Extend auger
 - Cover soil sensor

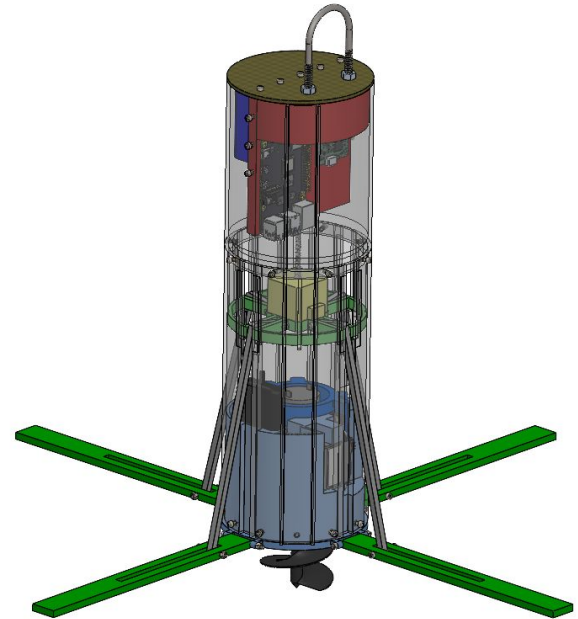
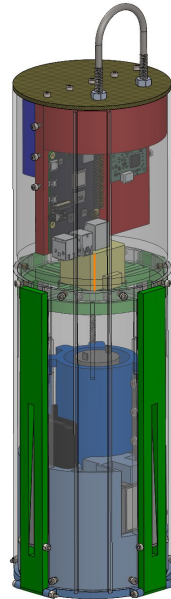



Payload Design: ZOMBIE

- 16.25 (in) tall, 5 (in) diameter
- Separates from Nosecone for drilling operations
- Uses an actuating collar to deploy legs to self-right

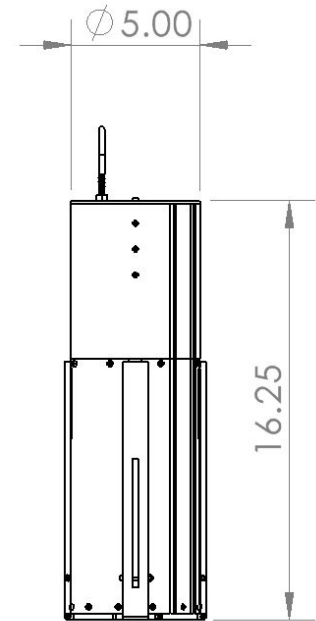
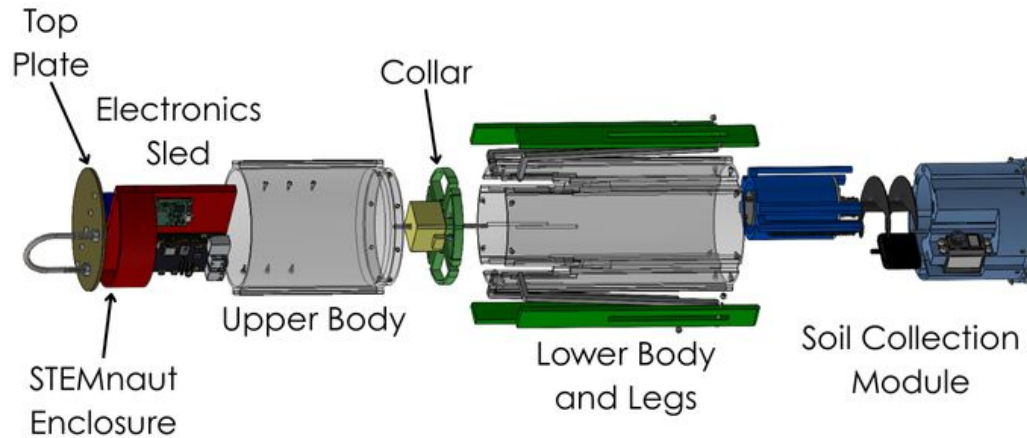



ZOMBIE Structural Design

- Lead screw inside ZOMBIE actuates to deploy legs
- Rack and pinion actuates drill vertically
- Planetary gear motor rotates drill
- STEMnauts are housed in top cap section
- U-bolt attached to cap to interface with GrAVE latch
- Main structure is split into sections for ease of assembly and modification

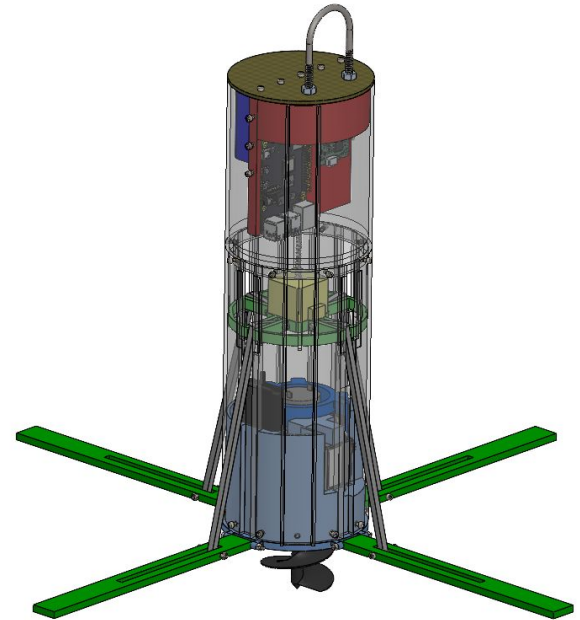



STEMnaut Housing

- Attached to ZOMBIE electronics sled
- Contains amenities
 - Control panel, water container, and TV
- Four STEMnaut ducks
 - Joel, Ellie, Shaun, and Robert
- Secured in seats with Velcro

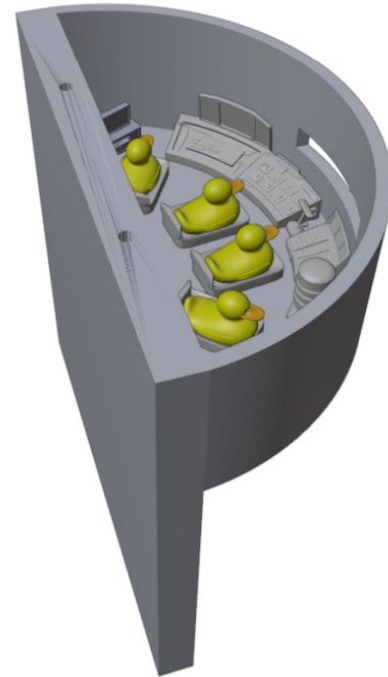



ZOMBIE Electronic Design

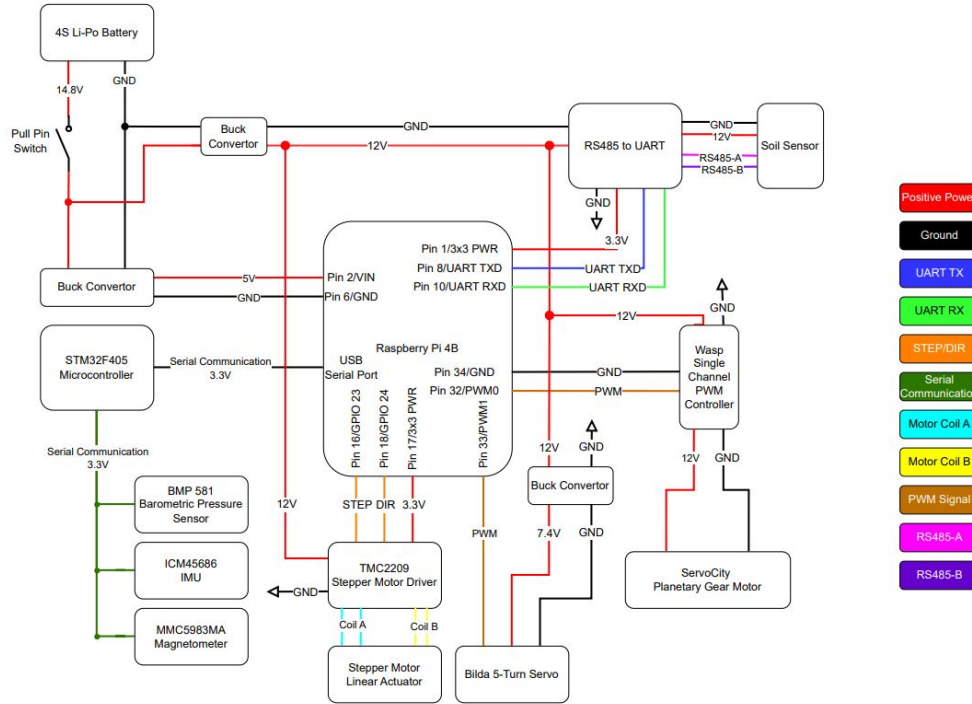



ZOMBIE Electronic Design

ServoCity Planetary Gear Motor

Max Torque (Stall)	417 oz-in
Operating Voltage	12V
Power Draw	12W

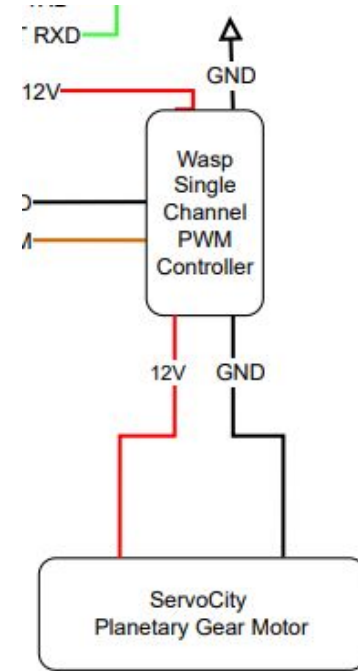

Wasp Single Channel RC Motor Controller

Max Current	10A
Max Voltage	26V



ZOMBIE Electronic Design

Bilda 5-Turn Torque Servo	
Max Torque (Stall)	350 oz-in
Max Rotation	1800°
Operating Voltage	7.4V
Power Draw	1.48W

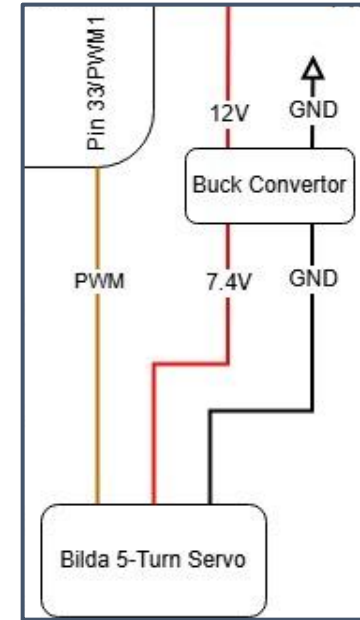



ZOMBIE Electronic Design

SparkFun Stepper Motor Linear Actuator

Maximum Linear Force	39.2 lbf
Rated Voltage	12V
Expected Current	0.4A
Power Draw	4.8W

Adafruit TCM2209 Stepper Motor Driver

Maximum Current	2A
Maximum Voltage	29V

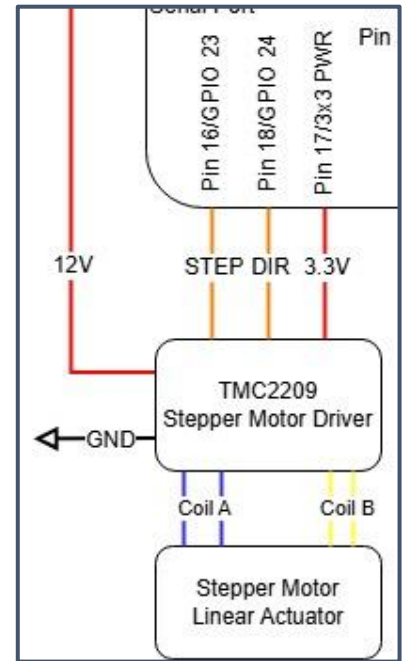
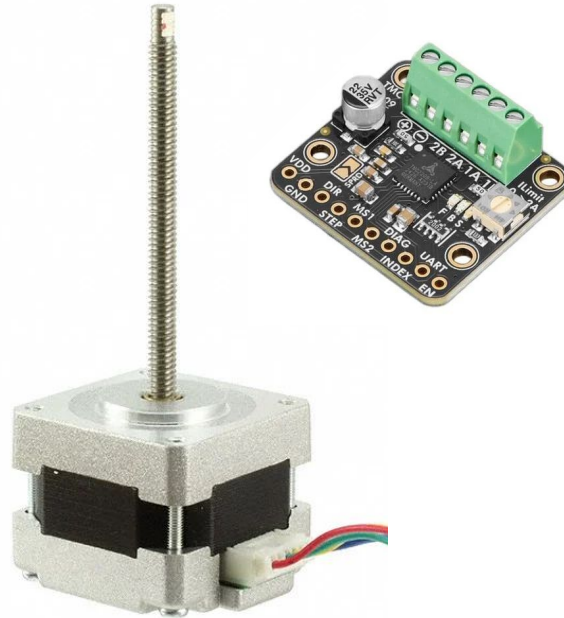



ZOMBIE Electronic Design

- Raspberry Pi 4B
 - Enough processing power to control all motors at once
- 4S Lithium-ion Battery
 - 4000 mAh
 - Changed from 2200 mAh in PDR due to the expected power consumption of all peripherals and the Raspberry Pi
 - Sufficient capacity for 3 hours idle with 15 minutes of operation.

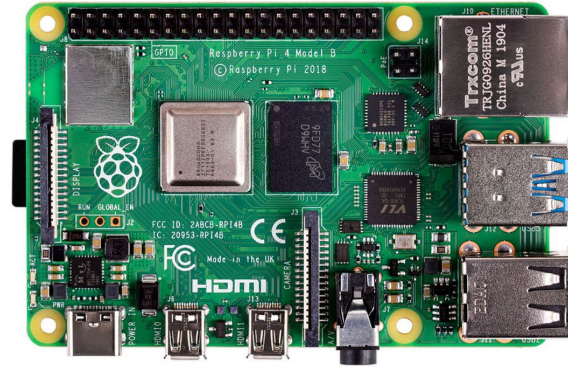



Payload Design: GrAVE

- Latch retains ZOMBIE during flight and releases upon landing
- Stepper motor actuates the lead screw with plate that pushes ZOMBIE out of the vehicle onto the ground

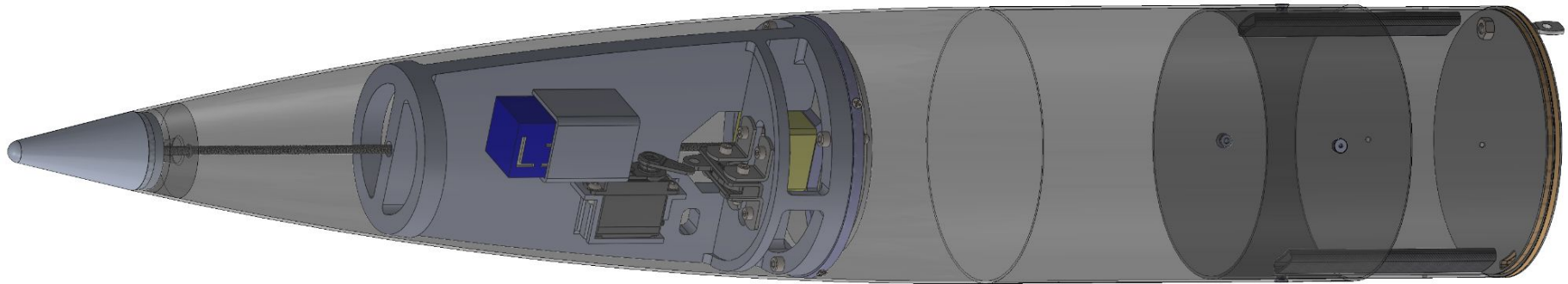



GrAVE Electronic Design

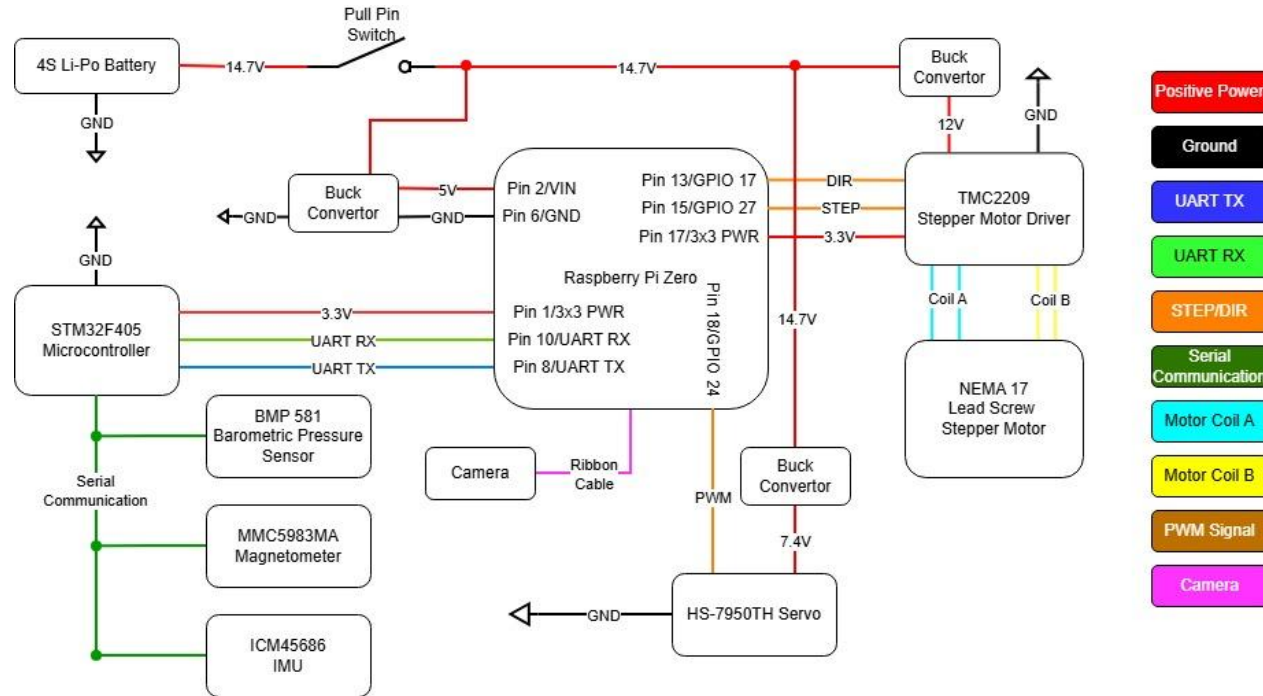



GrAVE Electronic Design

SparkFun Stepper Motor Linear Actuator

Maximum Linear Force	39.2 lbf
Rated Voltage	12V
Expected Current	0.4A
Power Draw	4.8W

Adafruit TCM2209 Stepper Motor Driver

Maximum Current	2A
Maximum Voltage	29V

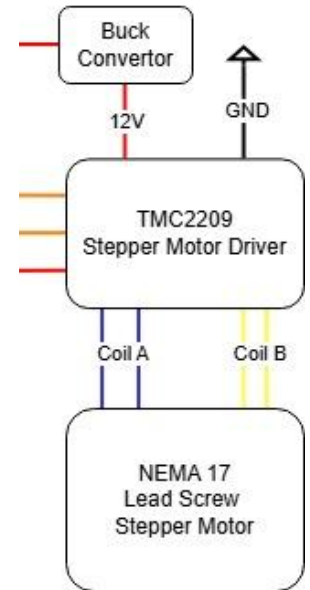
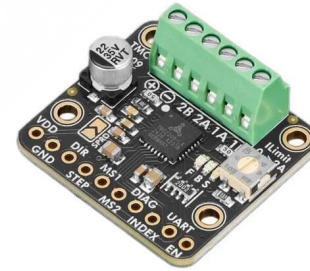
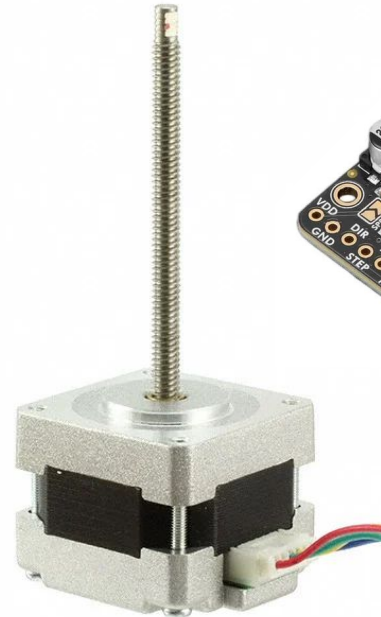



GrAVE Electronic Design

HS-7950TH Servo	
Expected Voltage	7.4V
Expected Current (Idle)	9mA
Expected Current (Active)	300mA
Power Draw (Idle)	0.066W

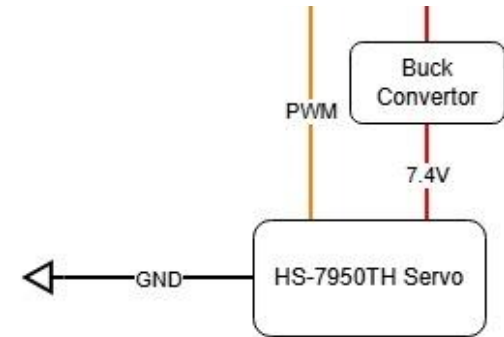



GrAVE Electronic Design

- Raspberry Pi Zero
 - Small form factor
 - Micro SD card slot attached
 - Same pinout configuration as Raspberry Pi 4B
 - Changed from Arduino Nano
 - Allows for streamlined programming
 - Included camera slot for video recording
- 4S Lithium-ion Battery
 - 2200mAh
 - 14.8V
 - Sufficient capacity for 3 hours idle with 15 minutes of operation.

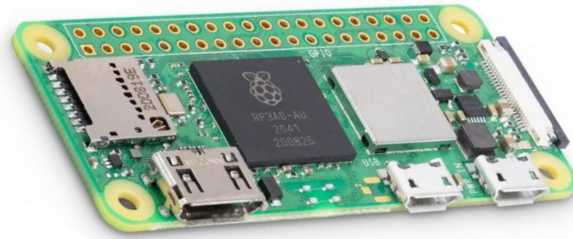



Air Brakes



Overview

Main Objective

- Active altitude control during the coast phase of the flight
- Achieve the target apogee with a 97% accuracy

Strategy

- Employ predictive apogee and control algorithms
- Actively adjust reference area during coast phase



Electronics



Raspberry Pi 5

- Central Computer
- 4 cores for fast data processing and control



Hiwonder HTD-85H

- Servo and Rotary Encoder
- 6.14 lb*ft torque at 11.1 V
- 9-14.8 V
- 5 A Stall current
- 0° to 240° servo angle



Electronics



Inertial Navigation System - INS

- ICM-45686 - 6axis IMU
- STM32F405RGT6 - Microcontroller
- MMC5983MA - Magnetometer
- BMP581 - Pressure Sensor
- All data for the Finite State Machine



Battery

- 2200 mAh 4s Li-Po
- Pad Idle time ~6 hr
- Satisfies requirement NASA VR 2.2



Manufacturing & Assembly

3D printed Components

- Air Brakes Housing
- Air Brakes Fins
- Mounting Sleds
- Gears

PCB Fabrication

- INS

COTS

- Electronics
- Threaded Rods
- Nuts, Screws, Bearings

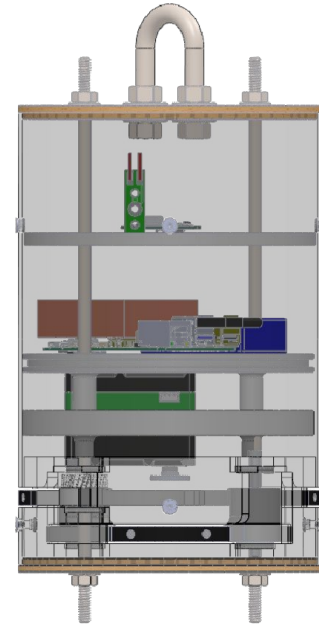



Manufacturing & Assembly

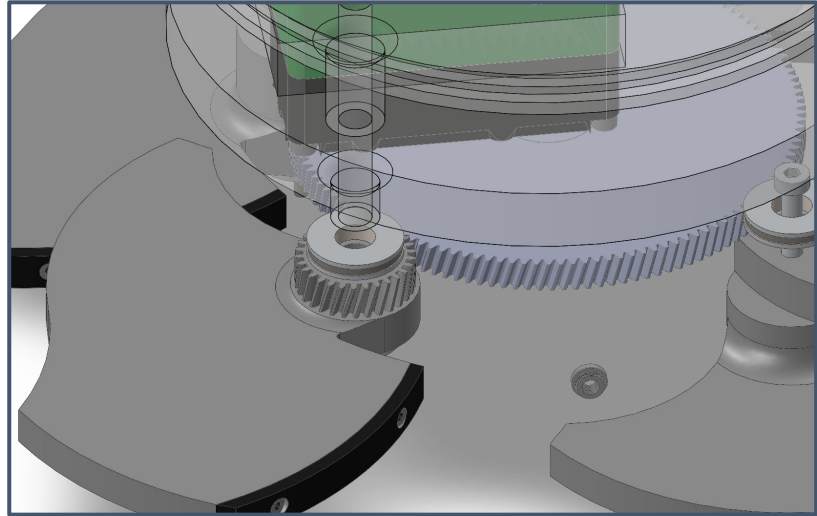
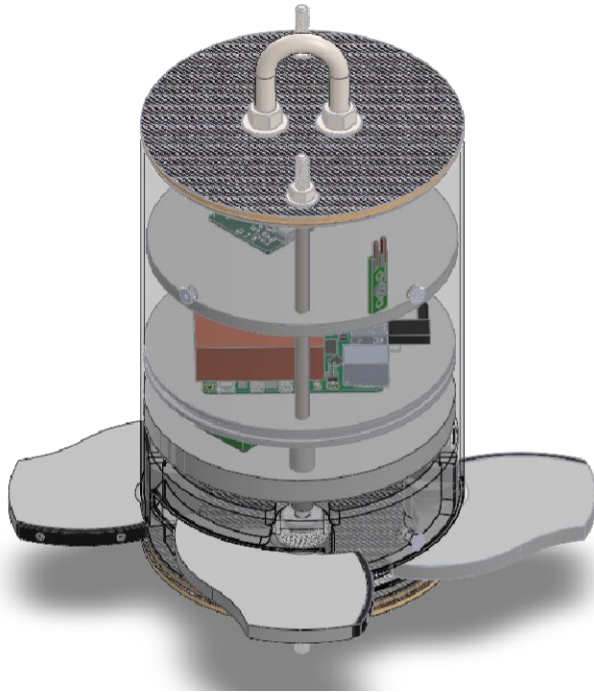



Drag Analysis

- Drag force per Mach vs Deployment level was simulated for a drag profile
- 96.416 lbf at 615 ft/s with Air Brakes Fully Deployed. 34.66 lbf at the same velocity with no Air brakes
- Contour gives a drag curve at various speeds for simulating Air Brakes effects on flight

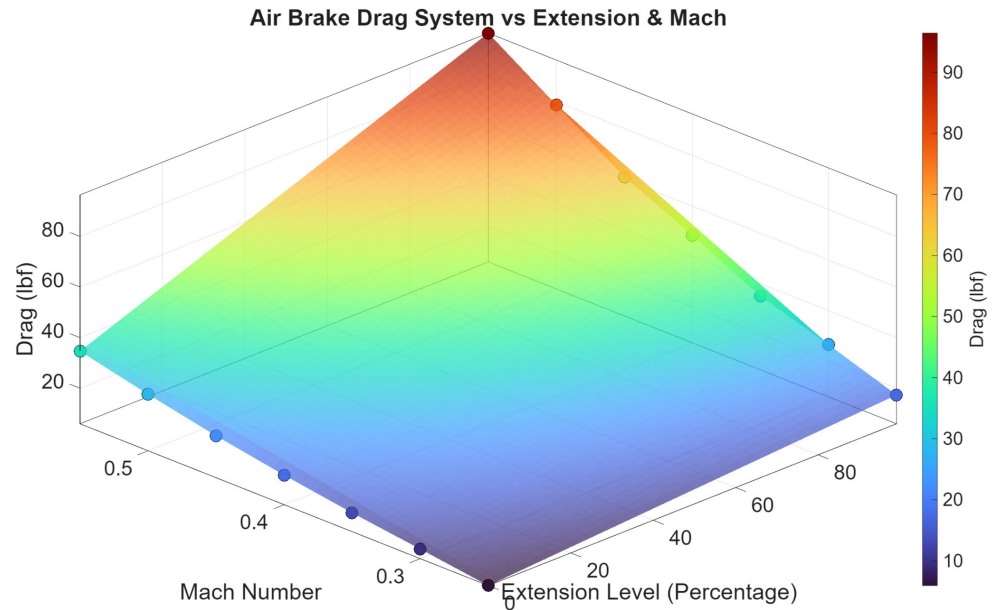



Software

Built as a finite state machine

- 5 distinct States
 - StandBy, Motor Burn, Coast, Free Fall, Landing
- Air Brakes only deploys in Coast State

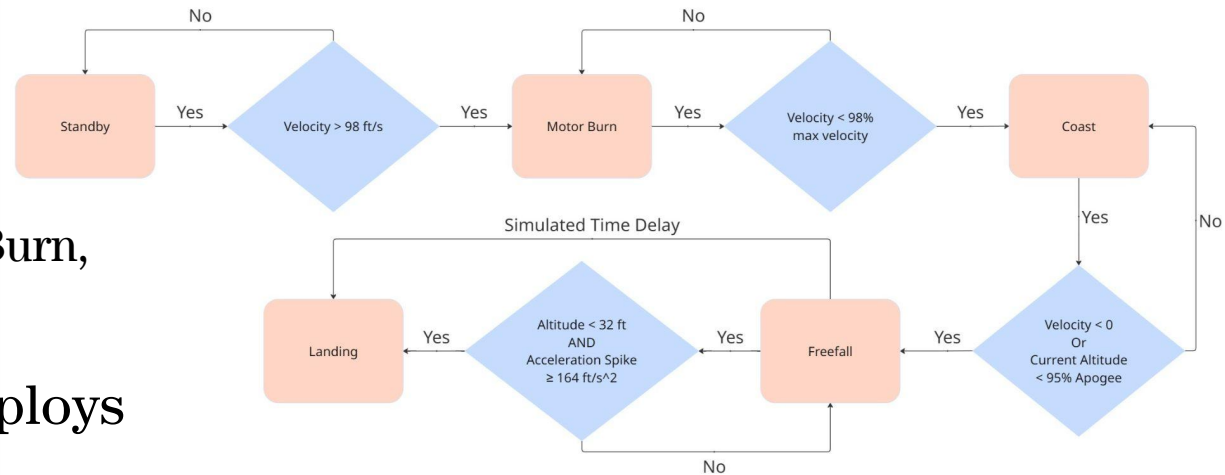



Flight Control Overview

- Bang-bang control scheme
 - Binary decisions for fin deployment
 - Reliable and less complex than an equivalent PID system
 - Takes in Launch Vehicle state and configuration
 - Determines apogee and deploys fins if Predicted Apogee is greater than Target Apogee

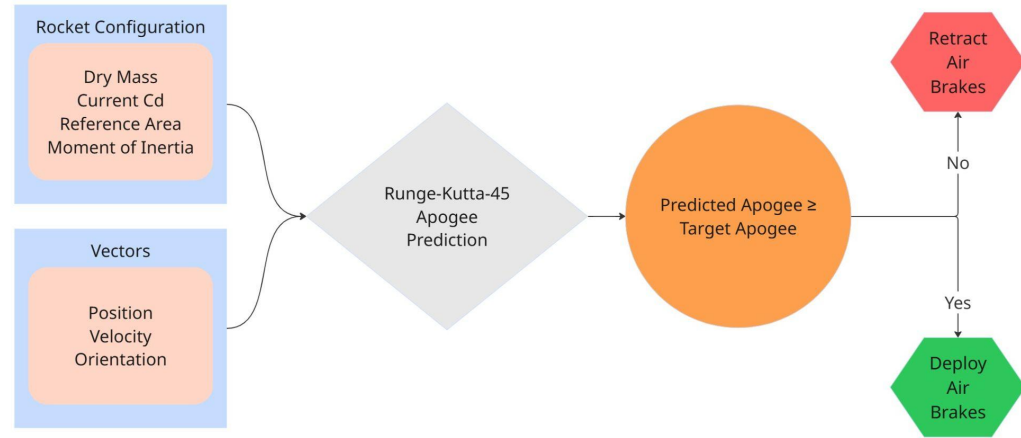



Apogee Prediction

Apogee Prediction rewritten from PDR

- Utilizes Runge-Kutta-4 integration strategy
- Simulates flight profile from the current state
- Performed every other clock cycle, 250hz

$$k_1 = f(y^*(t_0), t_0)$$

$$k_2 = f\left(y^*(t_0) + k_1 \frac{h}{2}, t_0 + \frac{h}{2}\right)$$

$$k_3 = f\left(y^*(t_0) + k_2 \frac{h}{2}, t_0 + \frac{h}{2}\right)$$

$$k_4 = f(y^*(t_0) + k_3 h, t_0 + h)$$

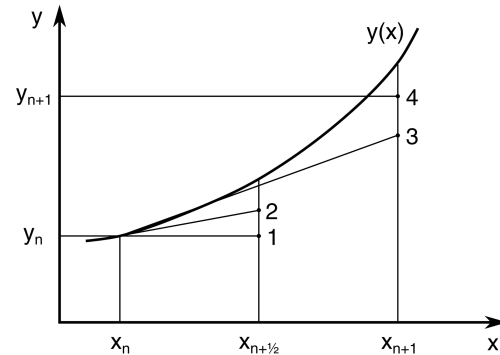



Trajectory Simulation

OpenRocket

- Custom Plugin running in loop of simulation
- Similar RK4 structure

RocketPy

- True apogee prediction ran at similar speed

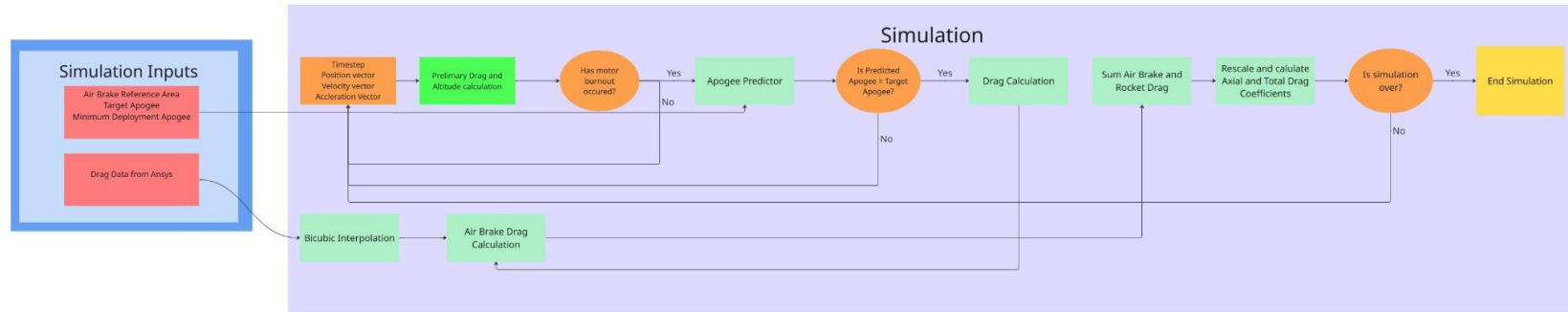



Subscale Flight Results



Subscale Design

- Approximate 2/3 scale
- Mimics full scale recovery
- Fiberglass body tubes
- Honeycomb core plates



Parameter	Subscale	Fullscale	Scale
Length (in)	80.1	110	72.8 %
Diameter (in)	3.98	6.12	65.0 %
CG (in)	46.6	66.1	70.5 %
CP (in)	63.1	85.2	74.1 %
Stability (cal)	4.15	3.13	-
Launch Mass (lbm)	12.1	36.9	32.8 %



Flight Conditions

Field Conditions	
Wind Speed	7.8 mph
Pressure	99800Pa
Temperature	64 °F
Launch Rail Cant	5°

Wind Profile Visualization

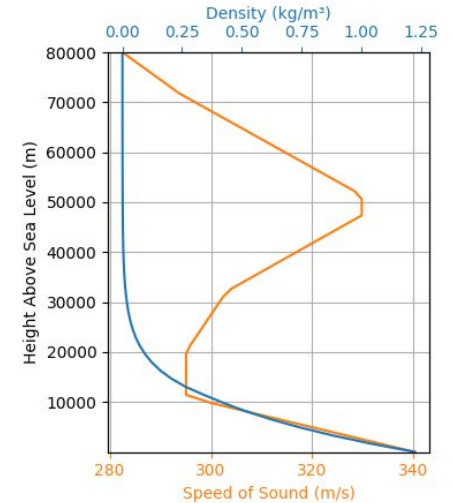
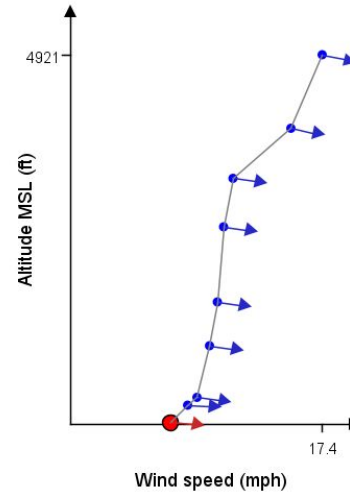

Subscale Launch

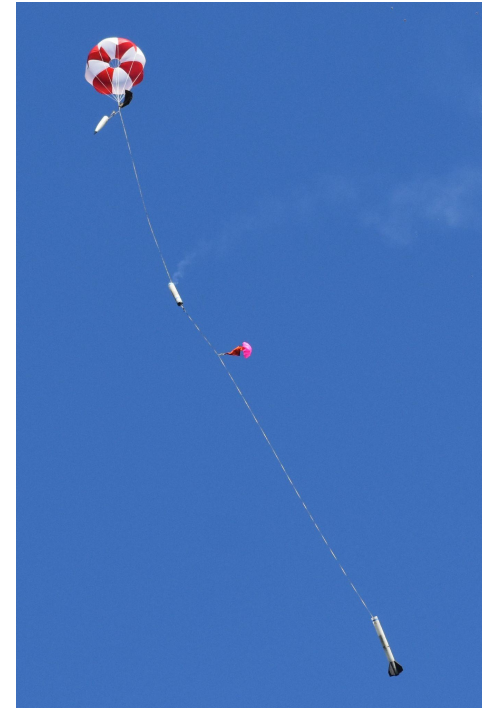



Flight Results

Recovery system operated as expected

- Drogue deployment at apogee with backup 1 sec after
- Main deployment at 550 ft with backup at 500 ft

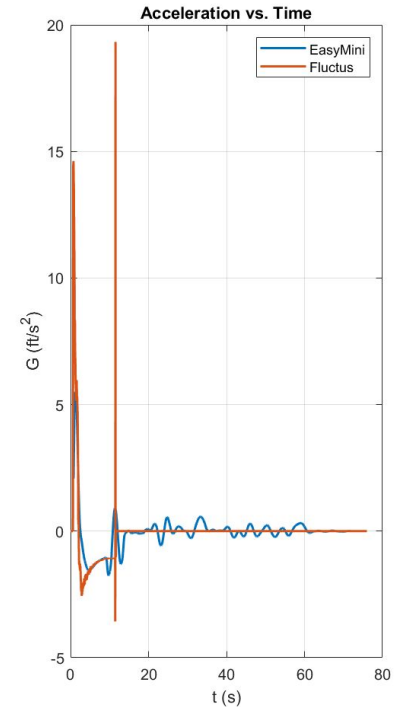
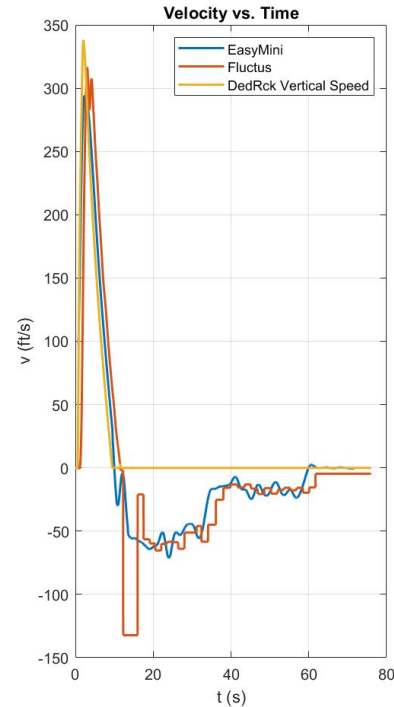
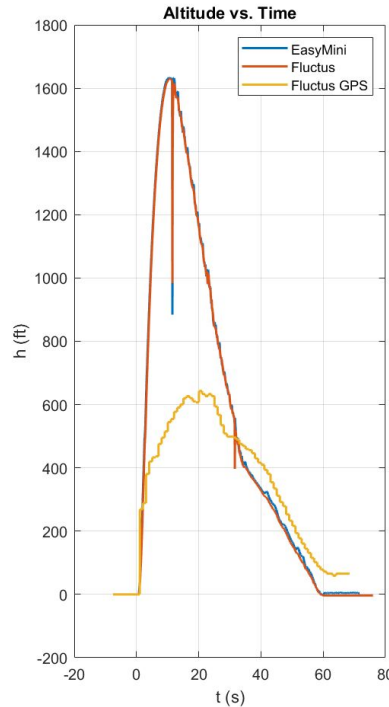



Recovery Landing Configuration



Nosecone

Main Chute



Drogue Chute

Main Bay



Fin Can



Predicted vs. Launch Day Flight

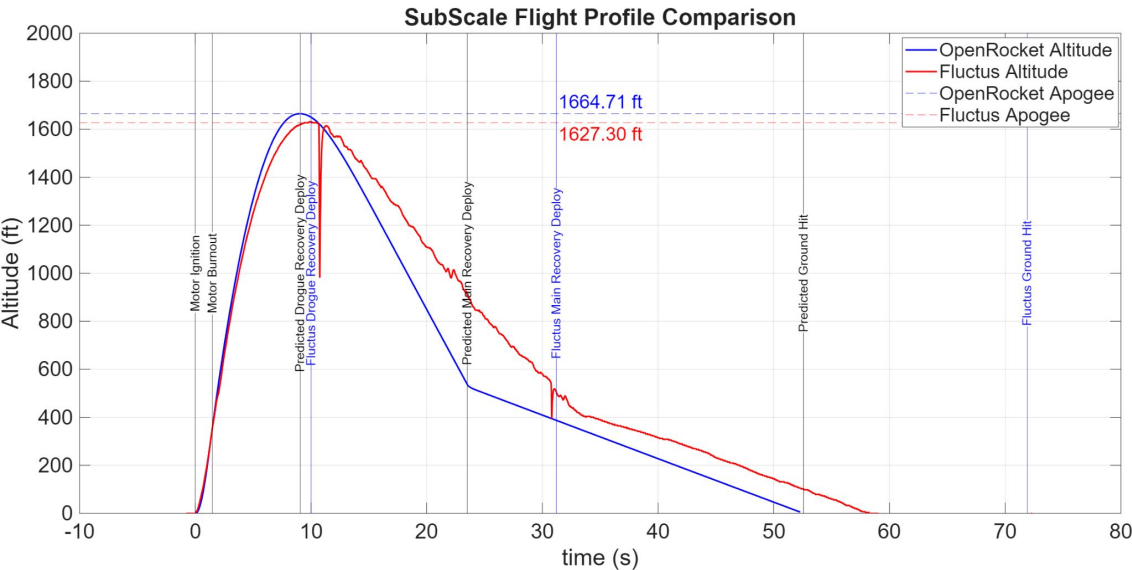

	Predicted	Fluctus	EasyMini
Apogee	1664 ft	1627 ft	1634 ft
Time to Apogee	9.03 s	10.01 s	10.06 s
Main Deployment	23.5 s	31.2 s	30.2 s
Time to Ground	52.6 s	71.91 s	67.16 s



Air Brakes Performance

- Apogee Without Air Brakes: 1897 ft
- Apogee: 1627 ft
- Target set to .25 seconds deployment after motor burn
- Prediction: 1667 ft
- Subscale veered upwind off the launch rail
- Decreased Apogee and increased flight times

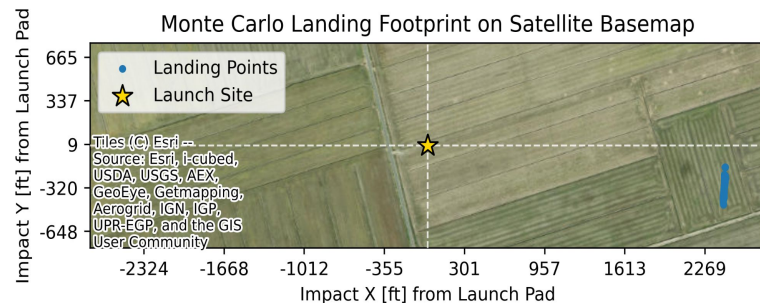



Descent Time

Total descent time higher than predicted

- Fin Can fell sideways
- Nearly doubled drag of the drogue parachute
- Weight distribution in Fin Can

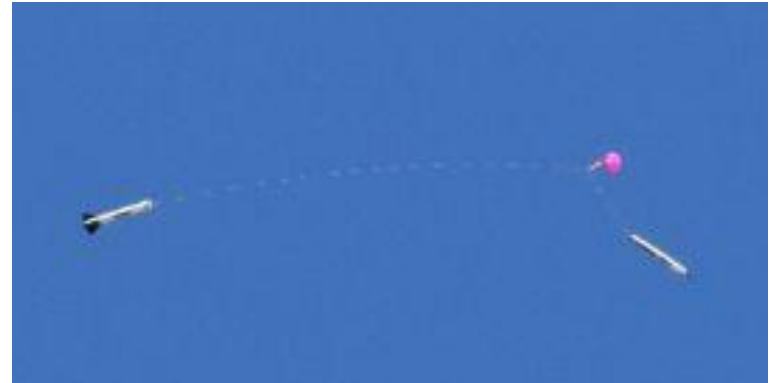



Requirement Verification



Requirement Compliance Update

- All Analysis requirements have been verified
- Testing requirements are scheduled and detailed in CDR
- Demonstration and Inspection requirements are planned to be completed by the FRR deadline

Requirement Type	Verified	Partially Verified	In Progress	Not Verified
NASA Requirements	47.30 % (35)	10.81 % (8)	40.54% (30)	1.35 % (1)
Team Derived Requirements	29.73% (22)	8.11% (6)	59.46% (44)	2.70% (2)



Test Plans and Procedures



Testing Suite

Test Name	Date Planned	Requirement/Hazard	Verification
Vehicle Test Suite			
Subscale Ejection Test	Oct 20th, 2025	RS 3, DHZ 12,13,14,31,32	Verified
Altimeter Test	Feb 9th, 2026	DHZ 28, 36	Not Verified
GPS Test	Feb 9th, 2026	NASA 3.12, RF 3	Not Verified
Parachute Drop Test	Feb 2nd, 2026	RF 7 DHZ 33,34	Not Verified
Fullscale Ejection Test	Feb 16th, 2026	RS 3, DHZ 12,13,14,31,32	Not Verified
AV Bay Tensile Test	Feb 8th, 2026	LVD 3, DHZ 11, 65	Not Verified
Fincan Tube Compressive Test	Jan 30th, 2026	LVD 2, DHZ 6,7	Not Verified
Fincan Drop Test	Feb 8th, 2026	LVD 1, LVE 4, DHZ 8	Not Verified
MOI Test	Feb 14th, 2026	~	Not Verified
Three Point Bend Test	Jan 30th, 2026	DHZ 6,7	Not Verified
Payload Test Suite			
ZOMBIE Self-Righting Test	Jan 17th, 2026	PF 3, PE 2, DHZ 40	Verified
ZOMBIE Drilling Test	Jan 24th, 2026	PD 5, PE 1	In Progress
GrAVE Deployment Test	Feb 7th, 2026	PF 2, PD 3, DHZ 45,46,48,56,59	Not Verified
Ground Simulation of Payload Hardware	Feb 14th, 2026	PF 2, PF 3, PD 3, PD 4, PD 5	Not Verified
Air Brakes Deployment Test	Feb 16th, 2026	AD 1,3, DHZ 19,20,66	Not Verified
Air Brakes Effectiveness Flight Test (VDF)	Feb 24th, 2026	AD 1,4, DHZ 21,22	Not Verified



Questions?
