



# Flight Readiness Review

---

March 25th, 2026



# Presentation Overview

---

- Payload Overview
- Launch Vehicle Design Overview & Verification Testing
- Recovery System Overview & Verification Testing
- Air Brakes Design Overview & Verification Testing
- VDF Results
- Launch Vehicle Requirements Verification
- Payload Design Overview & Verification Testing
- PDF Results
- Payload Requirements Verification
- Ground Systems



# Team Introductions



Elizabeth  
Team Lead



Donald  
Structures Lead



Aditya  
Aerodynamics Lead



Lauren  
Recovery Lead



Mason  
Payload Software Lead



Emily  
Payload Structures Lead



Ben  
Payload Electronics  
Lead



James  
Integration Lead



Aidan  
Safety Officer



# Payload Overview

---



# ZOMBIE and GrAVE

---

- ZOMBIE lander
- GrAVE deployment mechanism
- Stored in the Nosecone
- Retained with a latch mechanism





# Launch Vehicle Design Overview

---



# As-Built Launch Vehicle Dimensions

---

- Overall Length: 111.75 in
- Outer Airframe Diameter: 6.175 in
- Aspect Ratio: 18.1
- Sections: 3 Body Tubes, 3 Couplers, 1 Nosecone

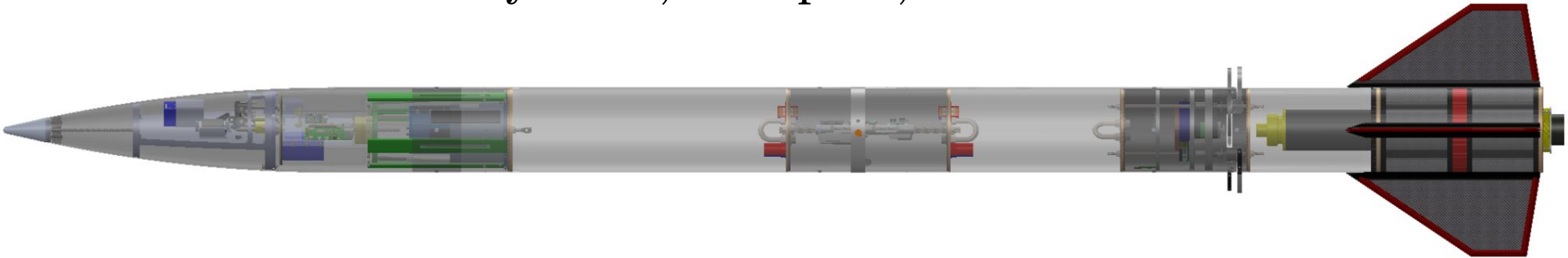



# Vehicle Separation Points

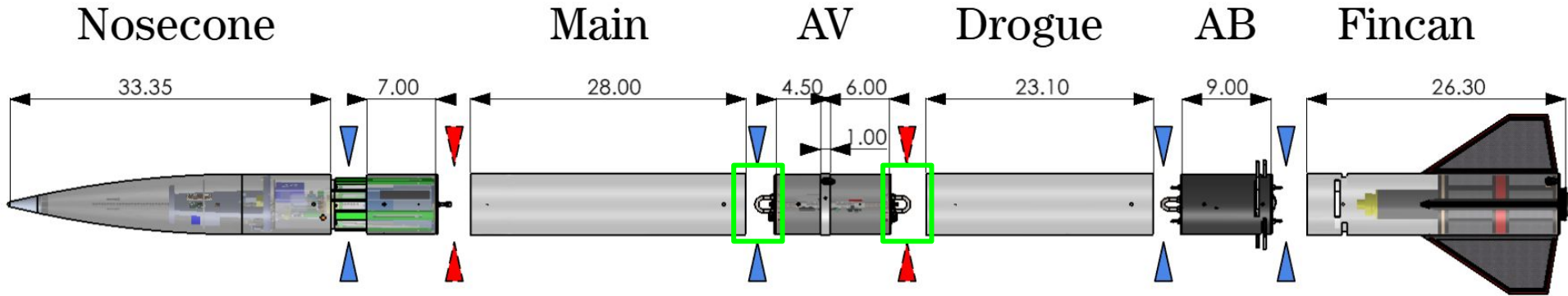

- Dual deployment system
- Main parachute forward of AV Bay
- Drogue parachute aft of AV Bay

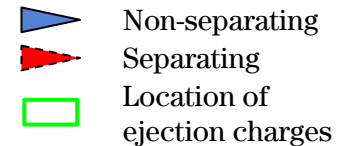



# Nosecone/Payload Bay

- 4:1 aspect ratio with a fiberglass body and 6061 aluminum tip
- Extended 9 in airframe diameter length
- 7 in coupler with mounts half way
- Epoxied forward main recovery cord





# Drogue and Main Parachute Bays



Drogue Parachute Bay  
23.1 (in) / planned 23.0 (in)

- 4 x 4-40 Nylon shear pin for in-flight separation points
- 4 x 6-32 Steel countersink screws and press fit inserts for non-in-flight separation points
- $\frac{1}{8}$  (in) vent hole
- Main bay PLA internal switchband for Nosecone Bulkhead placement



Main Parachute Bay  
28.0 (in) / planned 28.0 (in)



# Avionics Bay

- 11.5 in coupler tubing and 1 in switchband located 6 in from aft
- Stepped bulkheads (0.32 (in))
- Forward 1515 rail guide
- 2 x 3/8 in stainless steel U-bolts
- 4 x 1/4 in 6061 aluminum threaded rods for bulkhead retention





# Air Brakes Bay

---

- 9.0 in coupler tubing
- Stepped bulkheads (0.29 (in))
- 4 x rectangular fin slots
  - 0.52 (in) x 3.90 (in)
- 1 x 3/8 in stainless steel U-bolts
- 4 x 1/4 in 6061 aluminum connecting rods for bulkhead retention



# Fin Can

- Through-wall epoxy construction
- 3 x centering rings and 4 x fins
- Carbon fiber motor tube
- 6061  $\frac{1}{8}$  (in) aluminum motor retainer plate with 4 x 6-32 screws
- Forward Air Brakes slot cutouts
- Aft 1515 rail guide placement
- Bonding with System Three Gelmagic

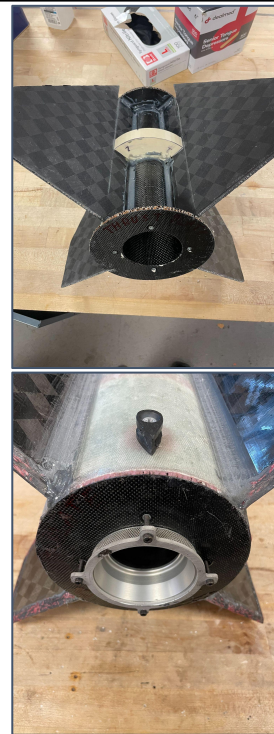

25.6 (in) / planned 25.5 (in)

# Fins and Fin Fairings

- 0.205 (in) thick honeycomb Nomex core with 7 ply quasi-isotropic face sheets
- Chopped tow carbon fiber fairings
  - Bonded with Gelmagic
  - Built-in chamfered edges
- Fin and Fairing dimensions
  - Semi-span = 6.0 (in)
  - Root chord = 14.0 (in)
  - Tip chord = 4.0 (in)
  - Sweep = 9.0 (in)

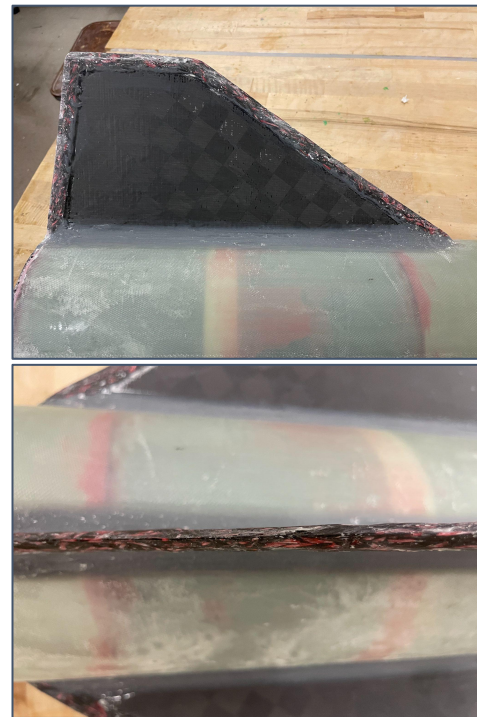



# Motor Selection

	Primary	Backup
Motor	L1390G	L1520T
Thrust to Weight	7.76:1	8:66:1
Rail Exit Velocity	74.5 (ft/s)	79.6 (ft/s)
Time to Apogee	17.4 (s)	16.9 (s)

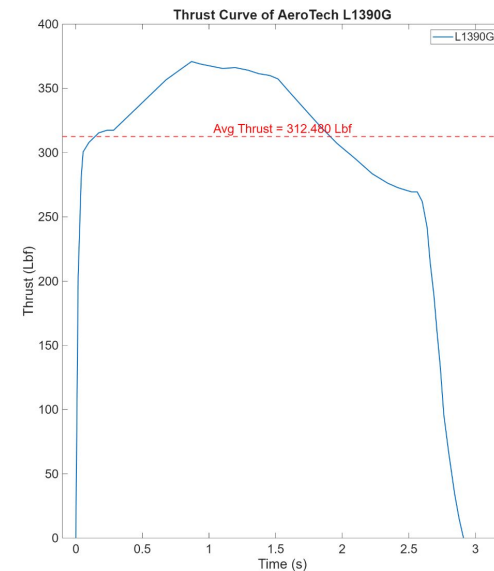
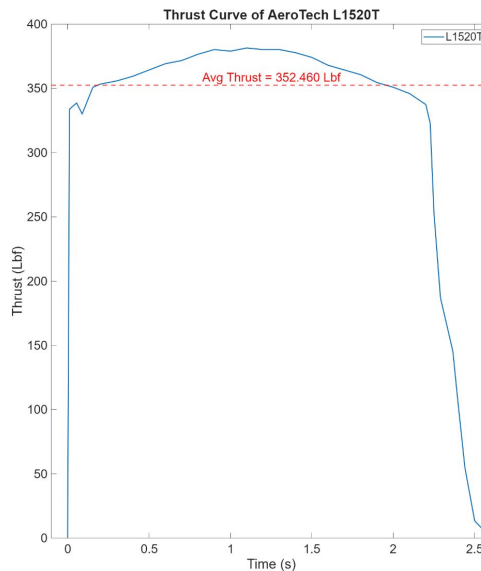



# Competition Altitude

- Declared Apogee is 4600 (ft)
- At any wind speed the Declared apogee is attainable within a 3 ft deviation

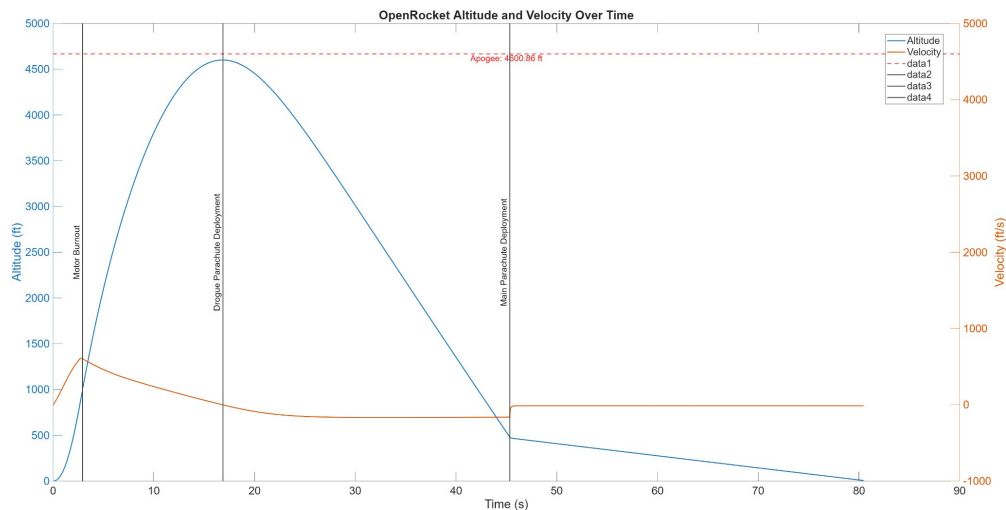

Wind Speed (mph)	Predicted Apogee (ft)	Target Apogee (ft)
0	4599	4610
5	4602	4635
10	4600	4640
15	4603	4655
20	4599	4680



# Stability

Software	Center of Pressure (in)	Center of Gravity (in)	Stability Margin (cal)	In front of Air Brakes Location (84.5 in)
OpenRocket	85.239	64.103	3.45	Yes
RocketPy	85.079	65.511	3.20	Yes

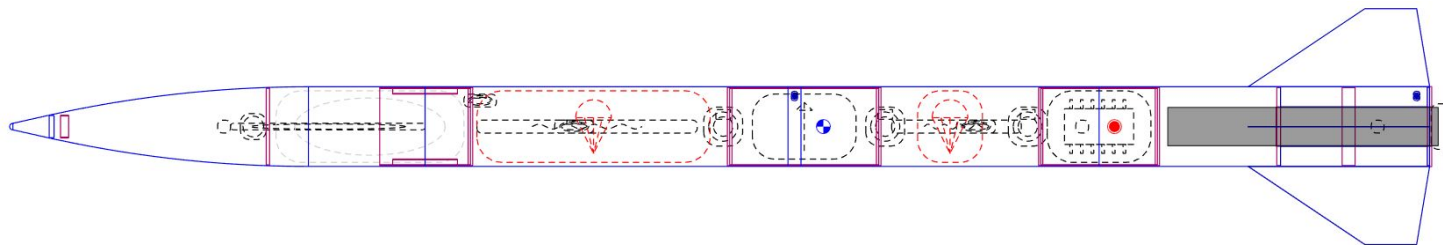
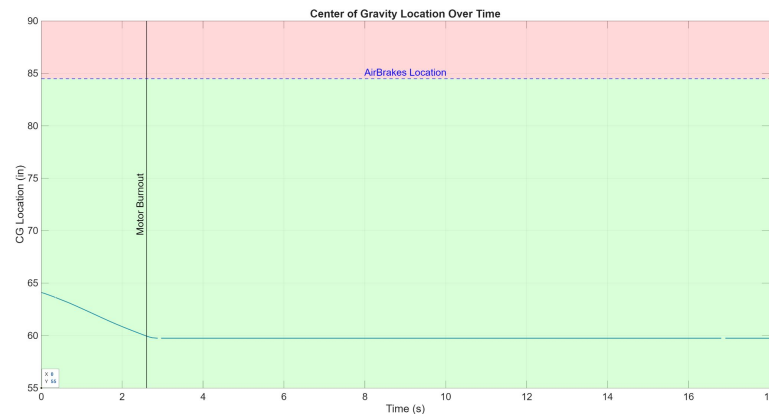



# Launch Vehicle Mass

Total Launch Vehicle Mass	
Configuration	Mass (lbm)
Dry Mass (Unballasted)	29.8
Dry Mass + Ballast	31.3
Total Wet Mass + Ballast	39.8
Burnout & Landing Mass	35.45

Total Launch Vehicle Mass			
Section	CDR (Est)	As Built	Difference
Nosecone/Payload Bay	11.20	11.942	+ 6.62%
Main Parachute Bay	4.58	4.179	- 8.76%
Avionics Bay	3.24	2.693	- 16.88%
Air Brakes Bay	3.05	3.303	+ 8.03%
Fin Can	12.92	13.275	+ 2.75%
Total (Wet + Ballast)	39.70	39.80	+ 0.25%



# Launch Vehicle Verification Testing

---



# Three-Point Bending Test

- 5 Samples with matching construction to Avionics Bay bulkheads
- 0.32 (in) Thickness
- Fiberglass face sheets
- Each sample individually measured for thickness and width



Test setup

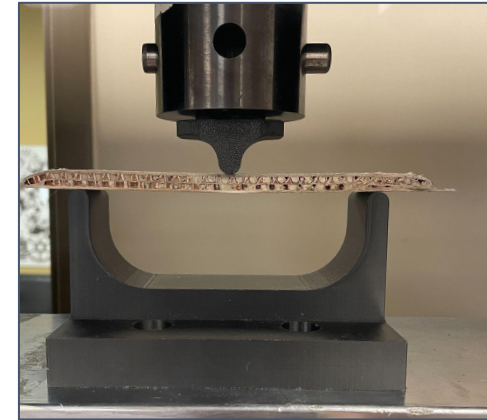

Shear failure



# Bulkhead Tensile Testing

- Avionics Bay bulkhead
- Matching construction and assembly, 4 x aluminum threaded rods,  $\frac{3}{8}$  (in) stainless steel u-bolt, washers, nuts
- Permanent deformation at 1100 (lbf) and ultimate failure at 1400 (lbf)
  - 2.7 x Factor of safety





# Fin Can Drop Test

- Complete Fin Can dropped
- Ballasted to 12.5 (lbs)
- Drop from 6.0 (ft)
- 75 (ft-lb) impact energy
- No noticeable cracking, deformation, or problems
- Slight angle for drop





# CG and Stability Test

- Determine the Center of gravity and overall stability of the launch vehicle
- Repeated for both Wet and Dry mass configurations
- Both CG locations are in front of Air Brakes protrusion

	CG Location Simulated	CG Location Measured	Stability Simulated	Stability Measured
Wet Mass	62.79 in	63.25 in	3.67 cal.	3.66 cal.
Dry Mass	59.07 in	59.43 in	4.28 cal.	4.20 cal.





# Moment of Inertia Test

- Determine and verify the Longitudinal Moment of Inertia
- Test completed a total of 6 times and results were averaged

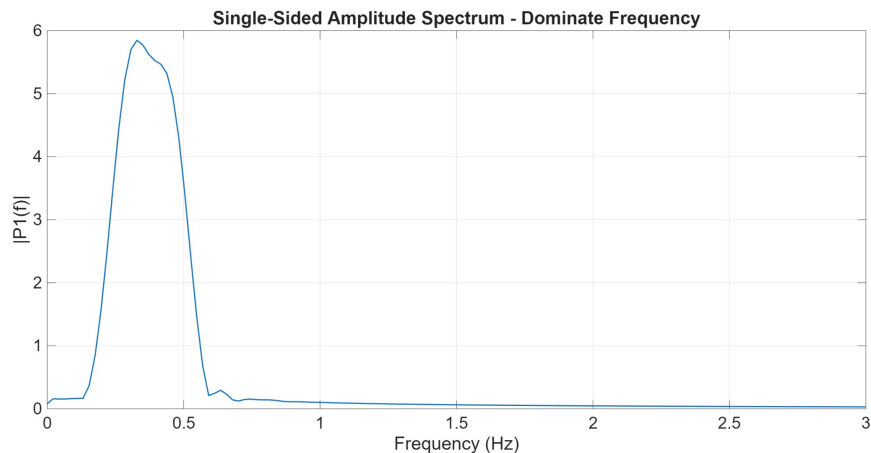

Simulated Value	Measured Value	Percent Error
282 lb*ft <sup>2</sup>	282 lb*ft <sup>2</sup>	0.71%



# Recovery System Overview

---



# Recovery Overview

## Drogue Deployment

- Apogee
- Secondary 1 second after primary

## Main Deployment

- 550 ft.
- Secondary at 500 ft.

All sections connected via shock cord with a minimum of 8 ft of separation between sections

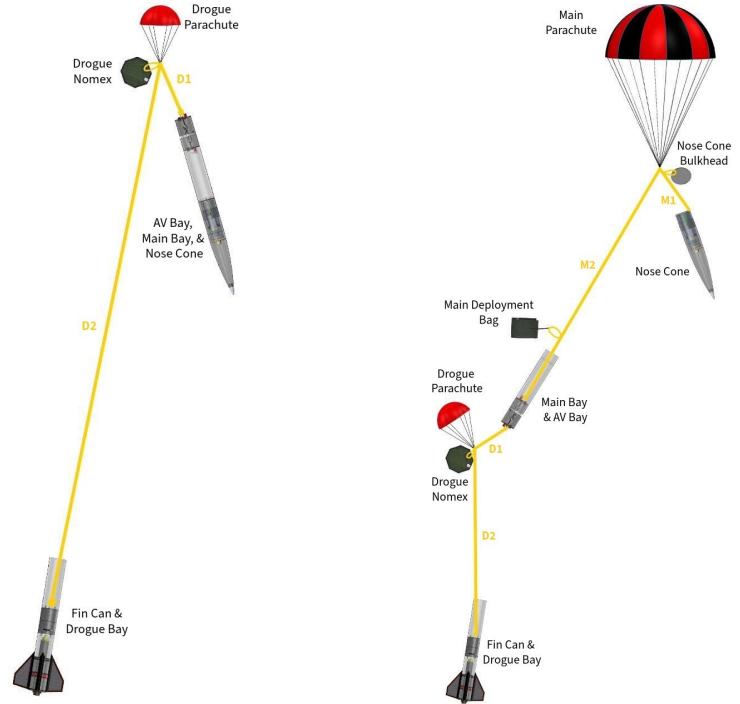



# Parachutes

---

## Drogue

- 15” custom elliptical
- Protected by Nomex blanket

## Main

- Fruity Chutes Iris Ultra 96” Compact
- Protected by Fruity Chutes Deployment Bag





# Recovery Harness

1/2" Kevlar shock cord

- 6000 lbf strength rating

1/8" Kevlar soft links

- 3 passes = 5130 lbf strength rating
- Soft links connect Alpine Butterfly loops on shock cord to U-bolts.

Nosecone attachment

- Knotted and epoxied into carbon fiber tube

Opening shock force = 339 lbf

Factor of Safety = 3.24

Drogue Shock Cord	Main Shock Cord
27 ft	28.5 ft





# Avionics

---

## Primary Altimeter: Silicdyne Fluctus

- Initiates drogue at apogee
- Initiates main at 550 ft.
- 7.4V 800mAh LiPo battery

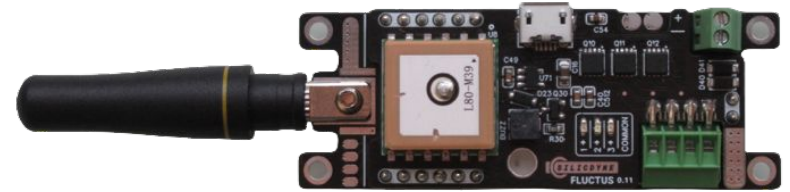

## Secondary Altimeter: Altus Metrum EasyMini

- Initiates drogue 1 sec after apogee
- Initiates main at 500 ft.
- 3.7V 500 mAh LiPo battery

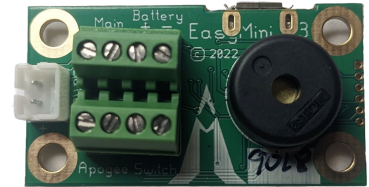

## GPS Tracking: Silicdyne Fluctus

- Transmits on a 900 MHz band
- SteadyBlue ground station



# Avionics Sled

- 3D Printed PLA
- All avionics mounted directly to sled
- Built-in slots for batteries, in addition to Velcro
- Wire clamps route igniter wires to in-line WAGO connectors
- Color-coded wires and charge wells

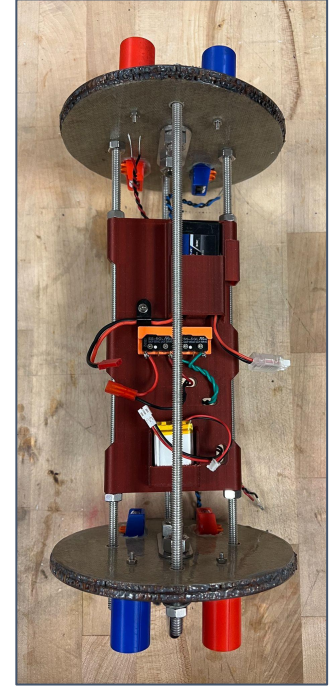
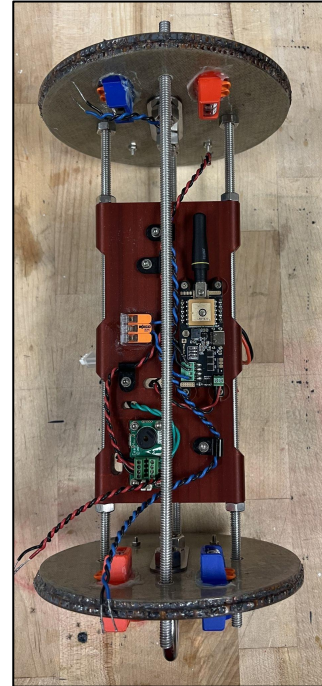



# Kinetic Energy

Max KE at landing = 64.3 ft-lbf

Section	Mass (lbm)	Drogue Descent Velocity (fps)	Kinetic Energy under Drogue (ft-lbf)	Main Descent Velocity (fps)	Kinetic Energy under Main (ft-lbf)
Fin Can, Drogue Bay	14.85	106.5	2615	16.7	64.3
AV Bay, Main Bay	5.02		3826		21.7
Nosecone	13.80		59.8		



# Descent Time and Drift Distance

For nominal flight with apogee of 4600 ft and main deployed at 550 ft:

- Descent time = 70.9 sec
  - Includes estimate for body drag based on VDF flight data
- Max drift = 2081 ft

Wind Speed (mph)	Drift Distance (ft)
0	0
5	520.2
10	1040
15	1561
20	2081



# Recovery System Verification Testing

---



# Altimeter Test

- Drogue and main LEDs lit up, indicating parachute deployment
- Altimeter data shows deployment at expected times/altitudes

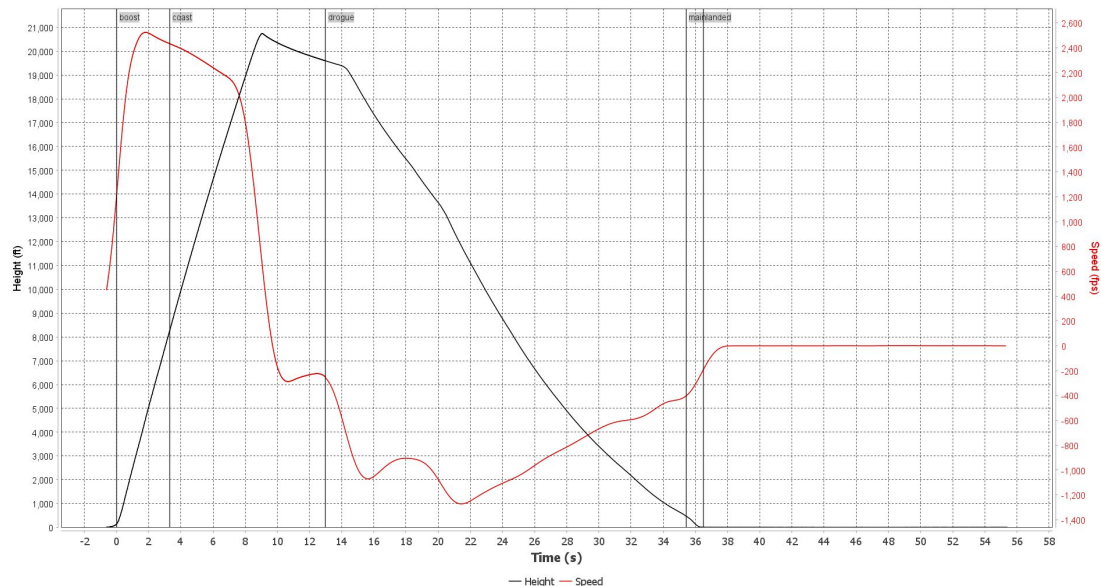



# GPS Test



- Fluctus GPS compared to cell phone GPS
- All Fluctus data points were within 30 (ft) of actual location



# Parachute Drop Test

- Verified aerodynamic performance of custom drogue
- Calculated a drag coefficient of 1.3
- Drop tested a commercial parachute of same size and design for comparison

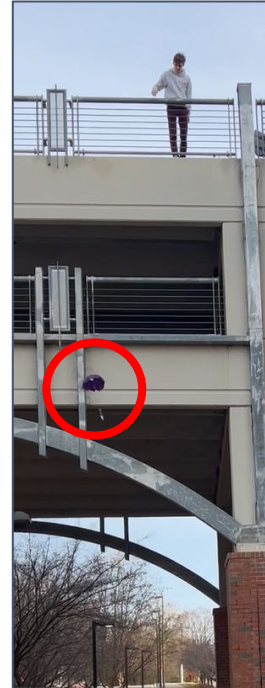



# Ejection Test

- Complete separation between Drogue Bay and AV Bay with 3.5 g of black powder
- Complete separation between Main Bay and Nosecone with 3.8 g of black powder
- No damage to Launch Vehicle or recovery system





# VDF Results

---



# Flight Results

Launch Date: 2/21/2026

Launch Angle:  $20^\circ$

Stability: 3.58 (cal.)

Average Wind Speed: 11.5 (mph)

Motor: L1390G

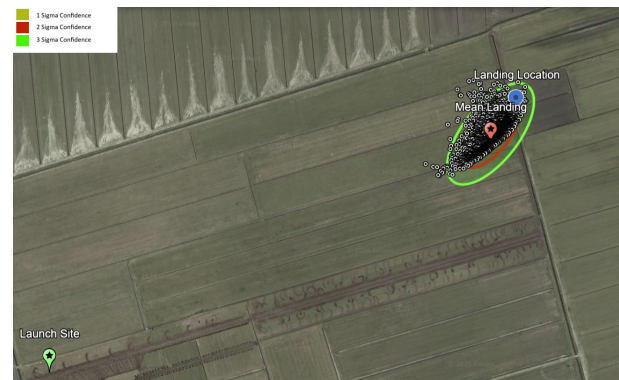
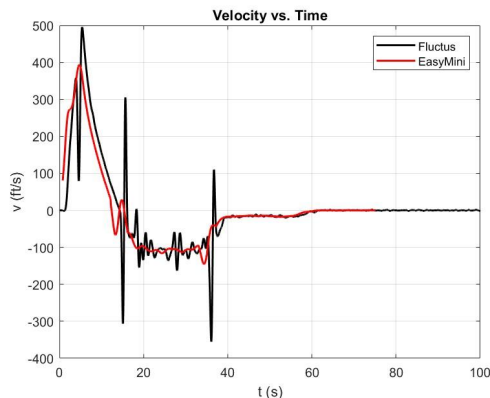
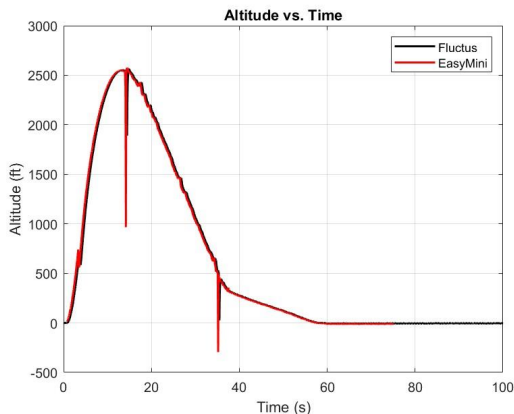



# Predicted vs. Actual Flight Data

- Predicted Apogee: 3603 (ft)
- Launch Day Apogee: 2566 (ft)
- Discrepancy due to high winds, high burnout stability with weather cocking, and high initial launch rail angle

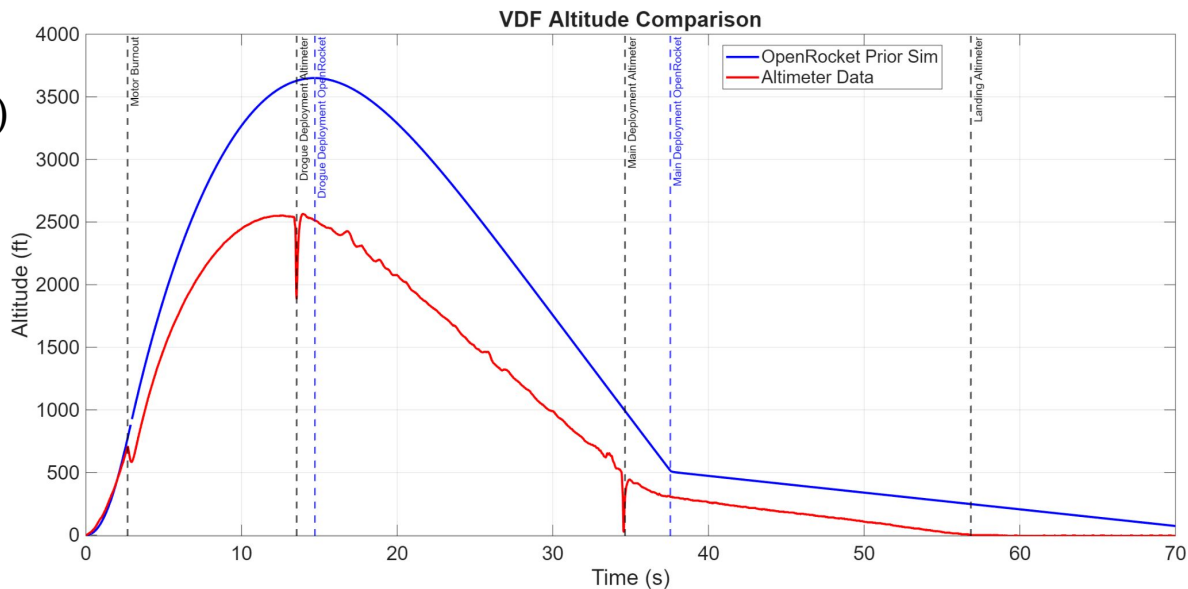

# Landing Configuration

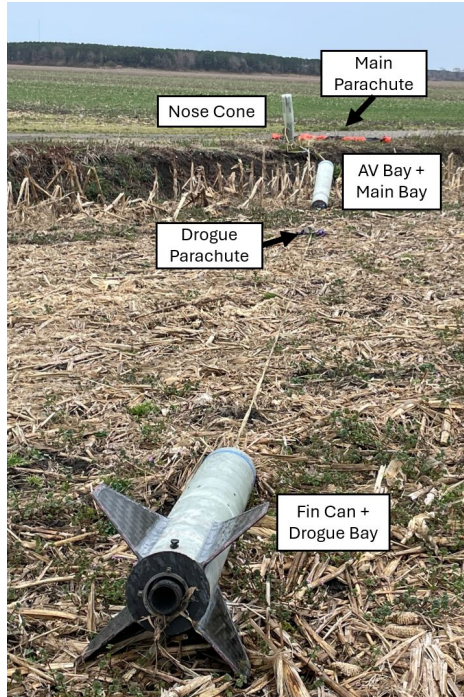

## AV Bay + Main Bay



## Nosecone





# Descent Data Comparison

- Lower descent time caused by lower apogee than expected
- Lower KE due to slightly slower main descent rate
- Descent velocity discrepancies due to imperfect body drag estimations

Parameter	Predicted Value	Actual Value	Percent Difference
Drogue Descent Velocity (fps)	103.0	107.2	+4.0%
Main Descent Velocity (fps)	16.7	15.7	-6.2%
Descent Time (s)	72.2	45.5	-45.4%
Fin Can + Drogue Bay KE (ft-lbf)	64.3	56.8	-12.4%
AV Bay + Main Bay KE (ft-lbf)	21.7	19.2	-12.2%
Nosecone KE (ft-lbf)	59.8	52.8	-12.4%



# Post Flight Analysis

- Simulated effective Launch Rail Angle
  - Simulated Apogee: 2581 (ft)
  - 20 (ft) discrepancy

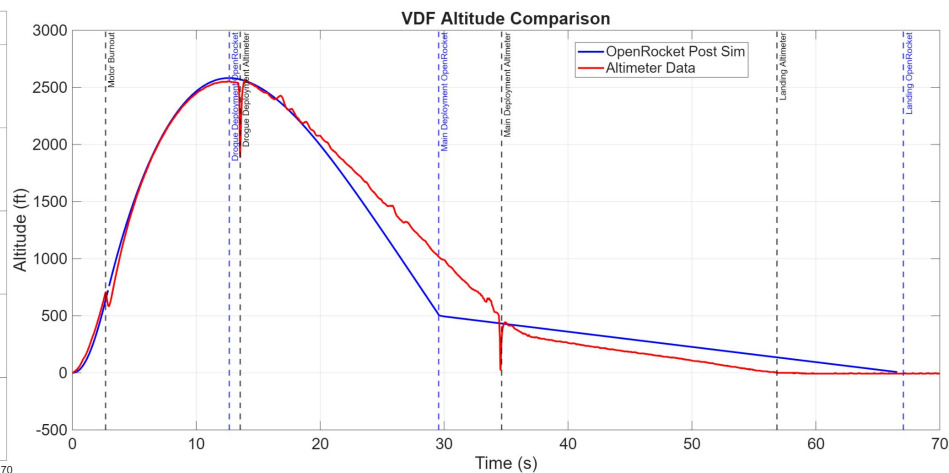
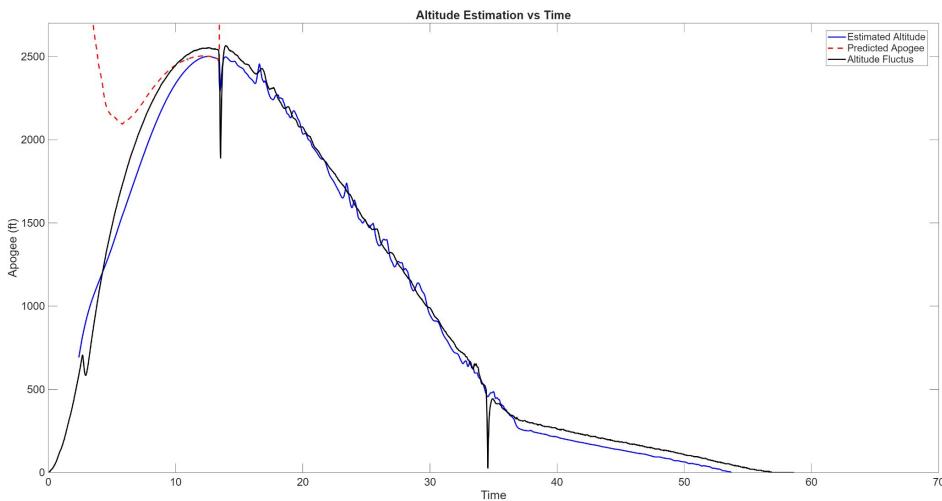



# Air Brakes Analysis

- Air Brakes deployed during flight
  - Predicted altitude on board was 60 (ft) under what the primary altimeter was reporting
- Deployed 0.4 seconds after motorburn
  - Correct Launch rail angle without Air Brakes: 2796 (ft)
  - 230 (ft) reduction
- On board camera footage
- Negative acceleration

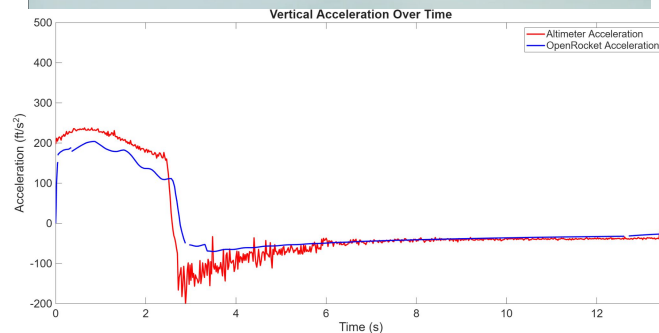
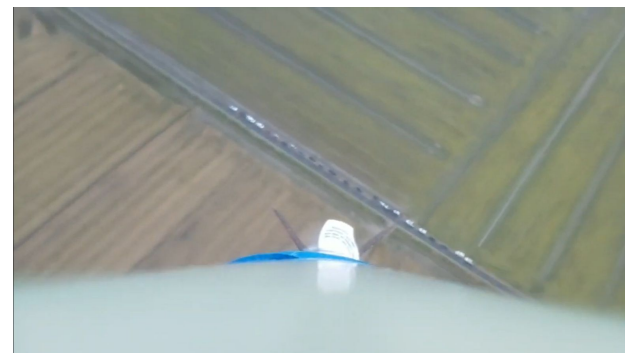



# Air Brakes Analysis

- Air Brakes increased CD by 0.24 during deployment
  - CD without Air Brakes: 0.393
  - CD during flight: 0.633
  - CD predicted with Deployment: 0.716

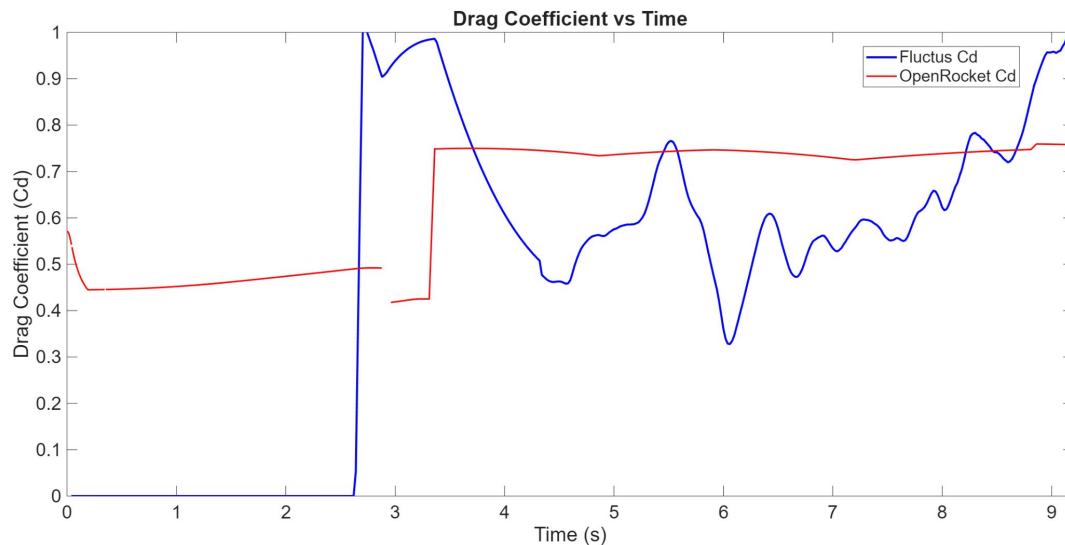



# Air Brakes Design Overview

---



# Finalized Design

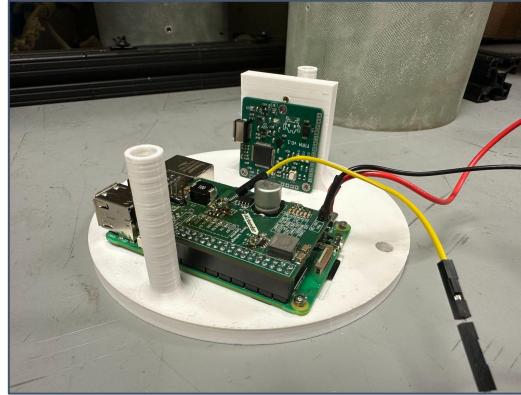
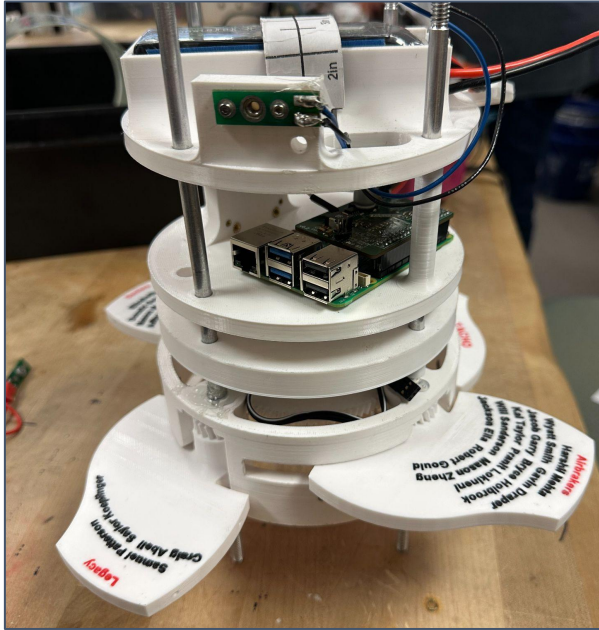



# Control and Software Algorithms

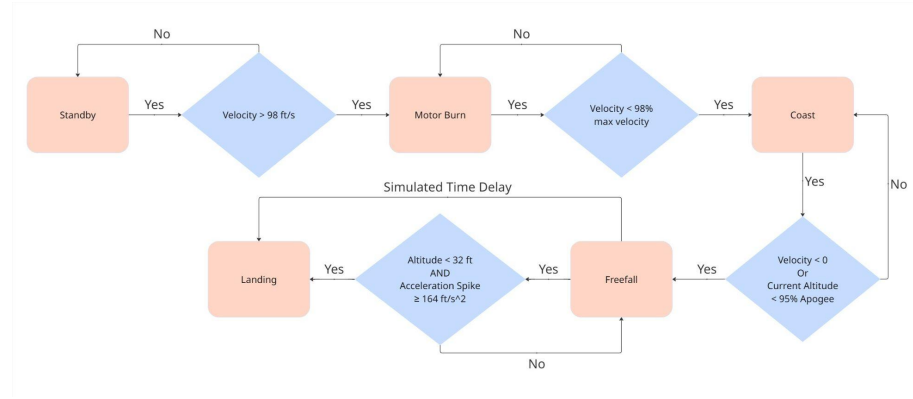
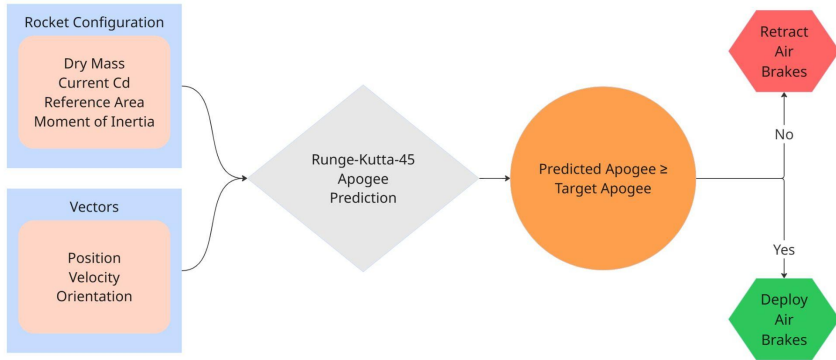



# Air Brakes Verification Testing

---



# Air Brakes Deployment Test

- Loaded each Air Brake fin through the Aerodynamic Center
- Successfully Deployed and Retracted upto 60 (lbs)
  - Did not go beyond
  - Plans for retesting before PDF
- Did not affect VDF flight due to high launch angle

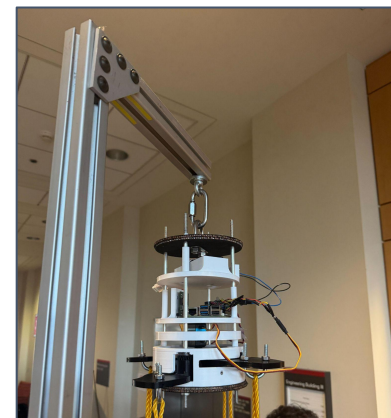



# Air Brakes Flight Effectiveness Test

---

- Prepare and Launch Air Brakes
- Increased Negative Declaration
- Proof of deployment with onboard camera

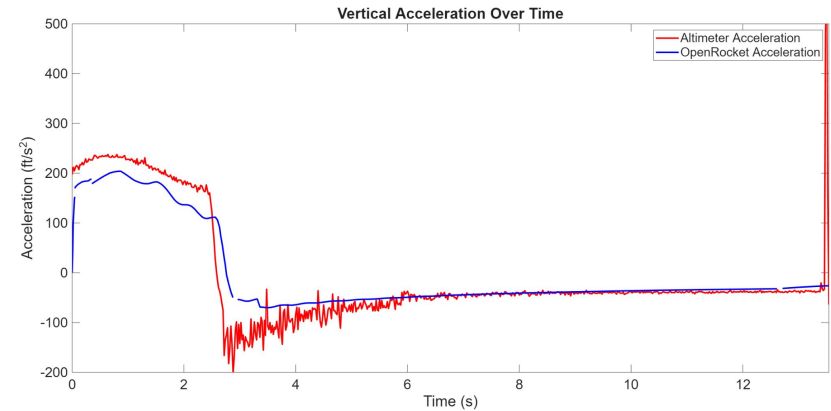
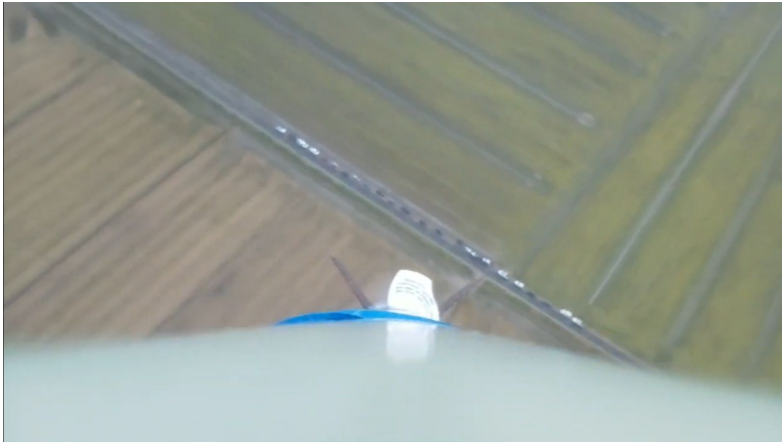



# Payload Design Overview

---



# Payload Design

---

- GrAVE Deployment Mechanism
- ZOMBIE Lander

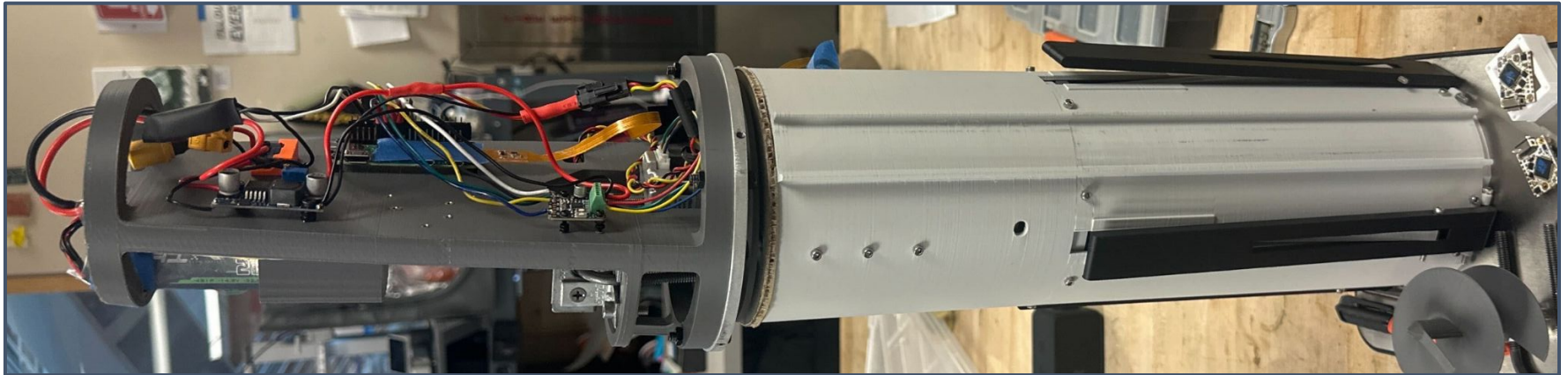

# Changes since CDR

---

- Various design solution attempts to fix ZOMBIE self-righting



- Split ZOMBIE batteries

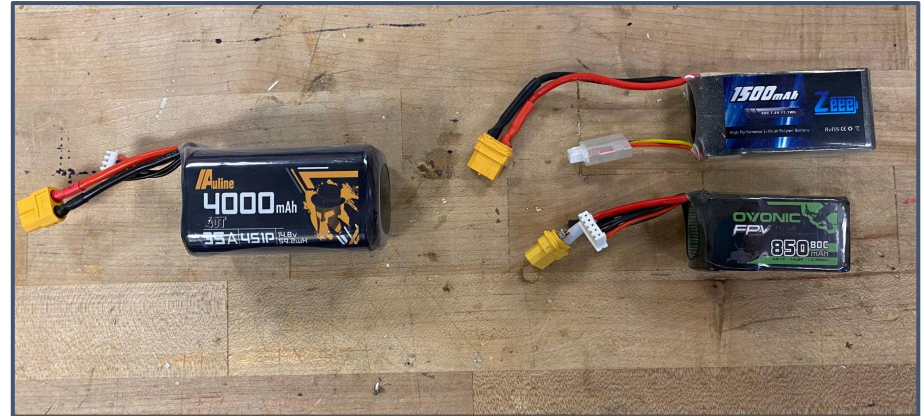



# Payload CONOPS

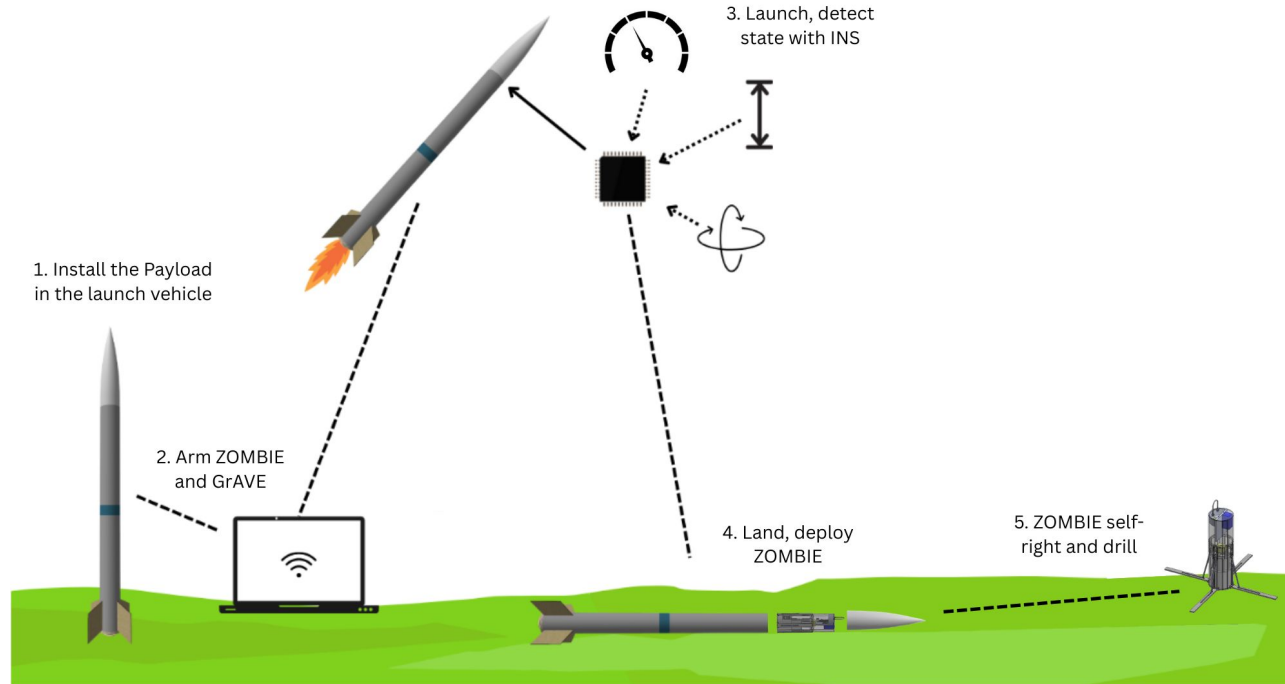



# ZOMBIE Overview

- Self-righting lander
- 16.31 (in) tall, 4.75 (in) dia.
- Retained by GrAVE
- Auger and soil sensor
- STEMnaut HAUS

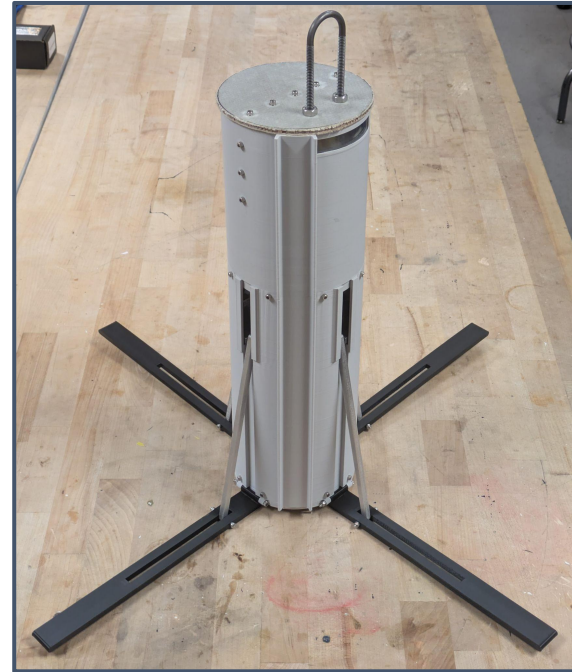



# ZOMBIE Manufacturing

- Lid-GrAVE interface
- Upper Body
- Lower Body
- Soil collection chamber
- Auger motor housing
- Leg system
- Electronics sled

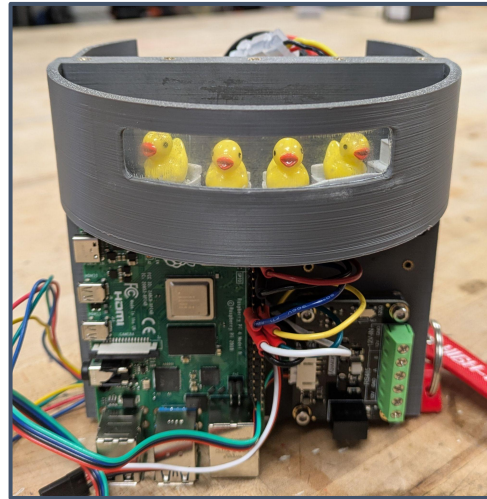



# ZOMBIE Electronic Design

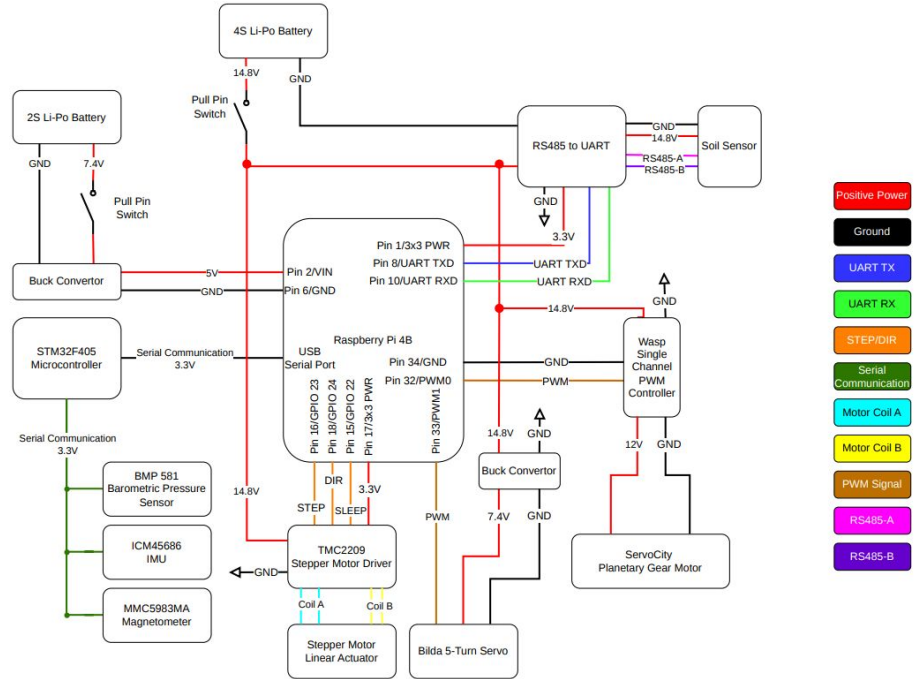
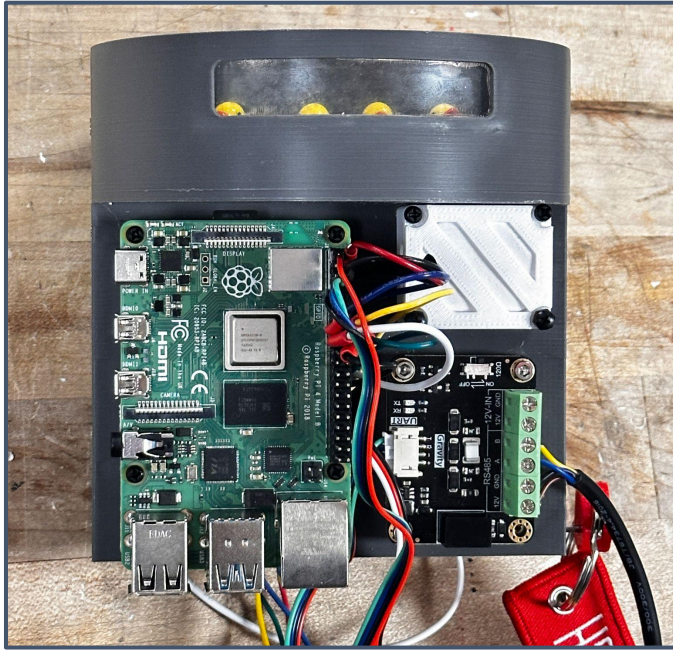



# ZOMBIE Electronic Design

- Sparkfun Stepper Motor Linear Actuator
- A4988 stepper motor driver
- Connected to 4S 850mAh LiPo

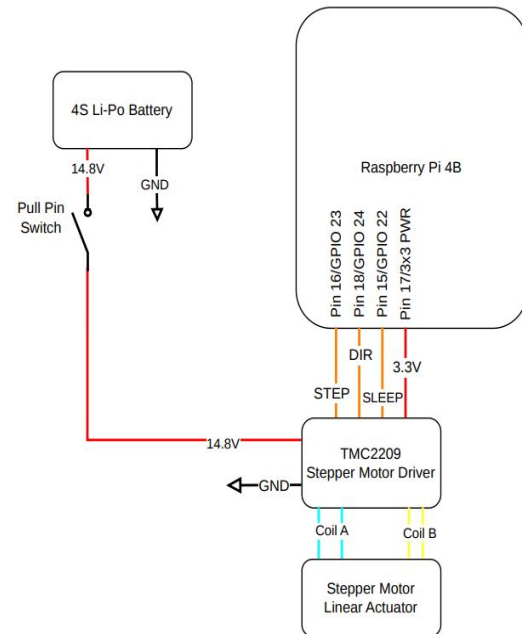
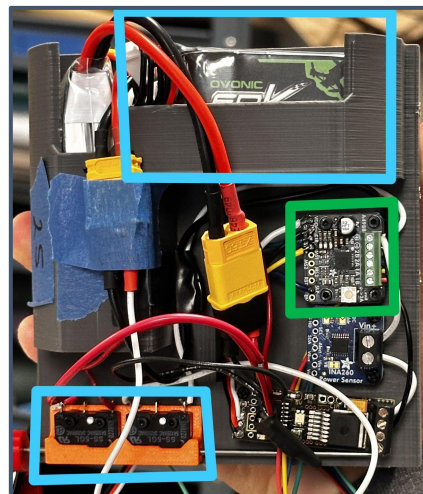
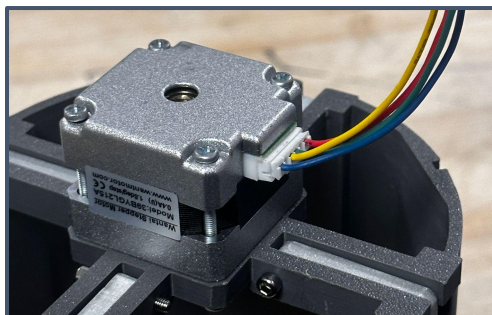



# ZOMBIE Electronic Design

- Servocity Planetary Gear Motor
- GoBilda 5-turn high torque servo
- INA260 Current Sensor
- Wasp R/C Motor Controller

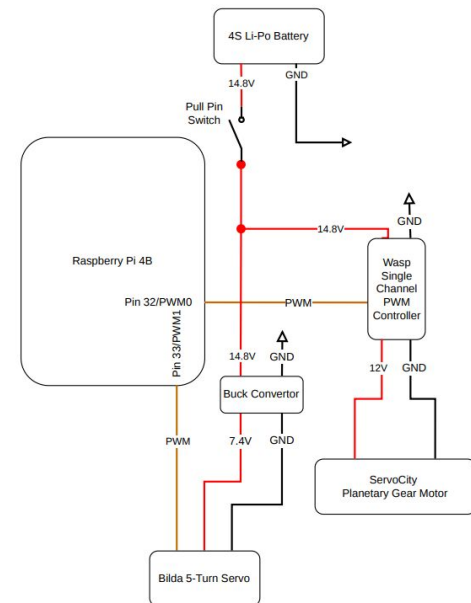
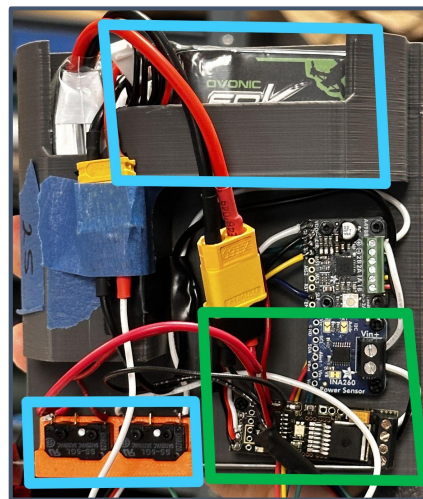
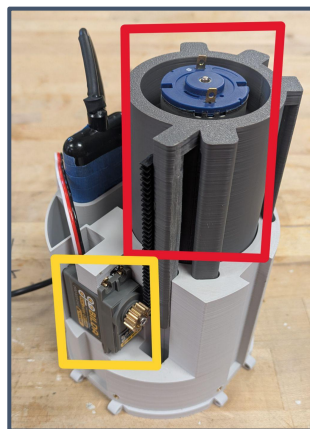



# GrAVE Overview

- Retains ZOMBIE
- 10.38 (in) tall
- Latch mechanism
- Pusher plate
- Located in Nosecone

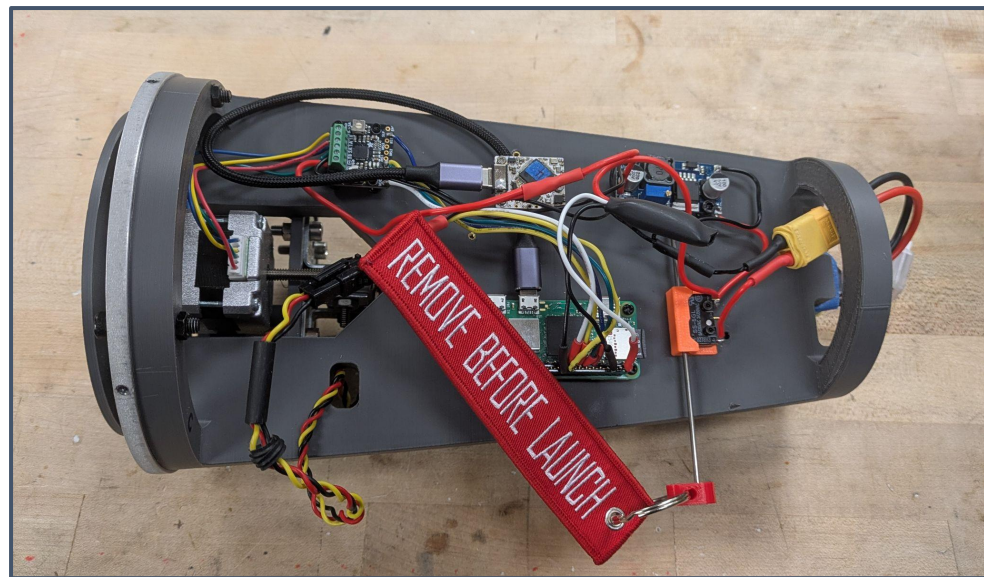



# GrAVE Manufacturing

- Electronics sled
- Latch mechanism
- Pusher plate
- Aluminum mount
- Camera

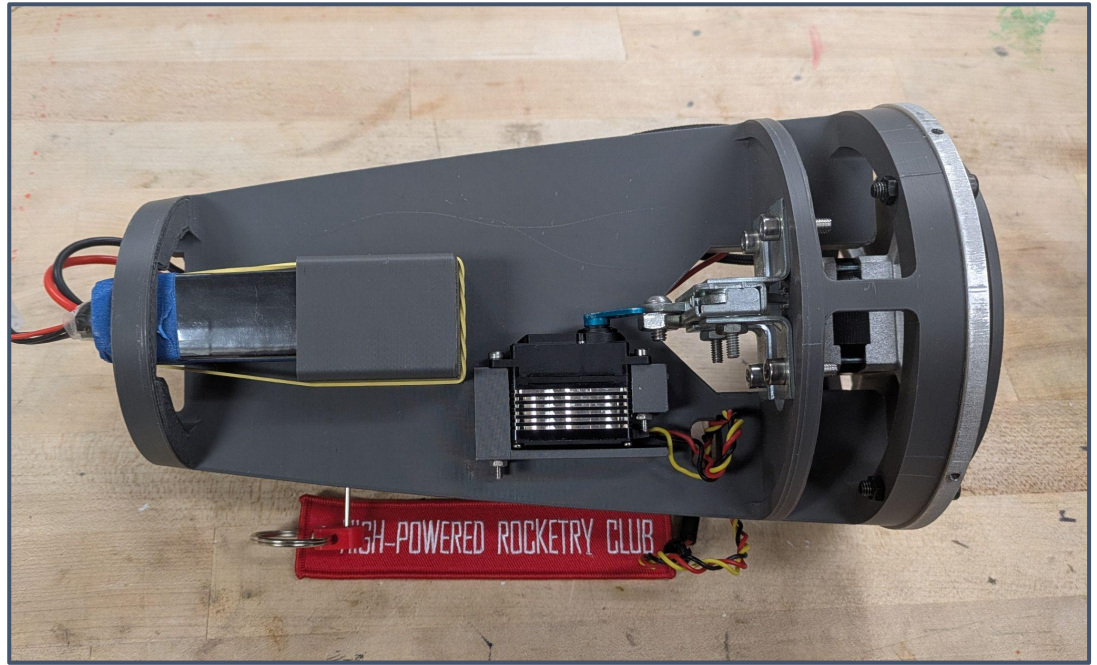

# GrAVE Electronic Design

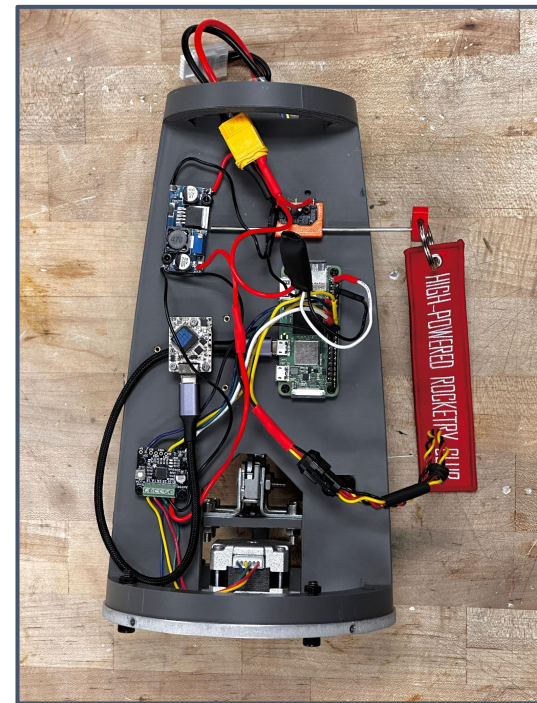
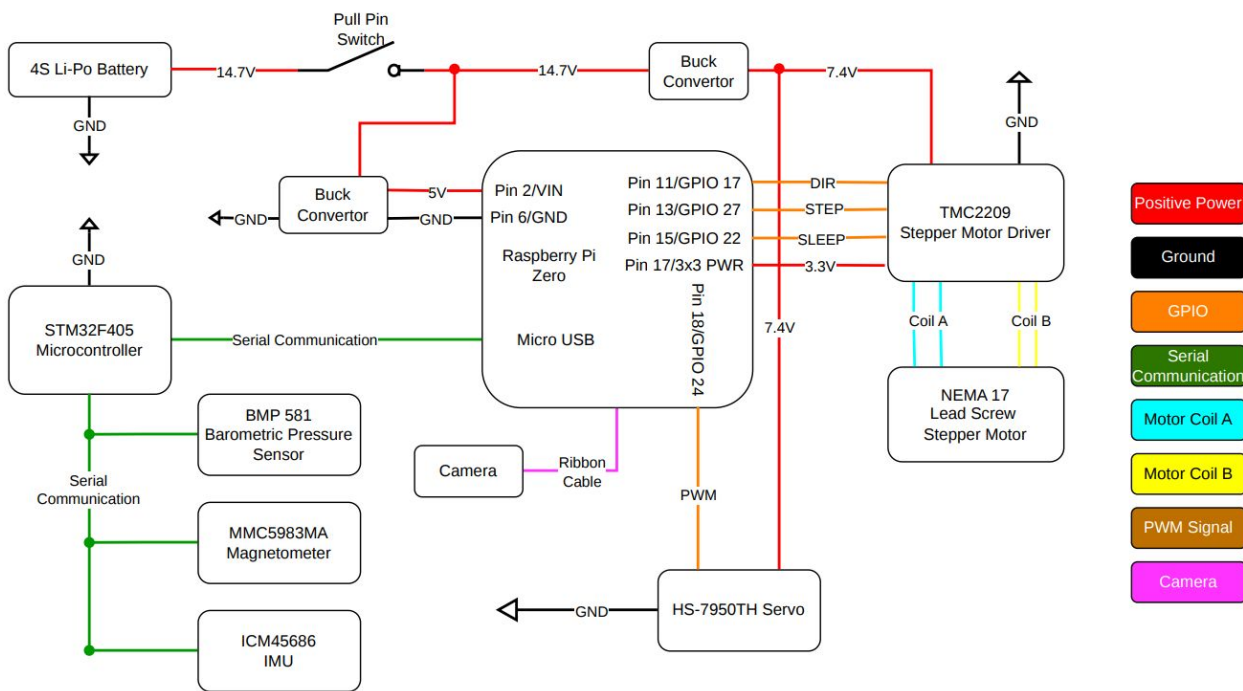



# GrAVE Electronic Design

- HiTech HS-7950TH servo
  - Actuates mechanical latch
- SparkFun stepper motor linear actuator
  - A4988 stepper motor driver

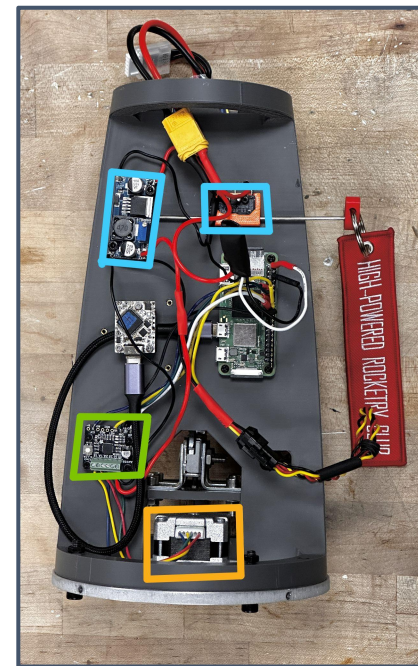
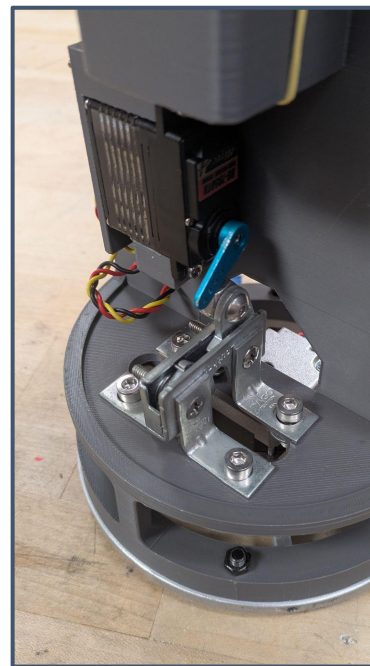
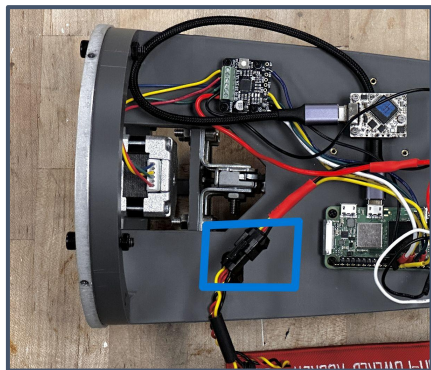



# GrAVE Electronic Design

- Raspberry Pi Camera
- Connected to GrAVE
- Used to satisfy requirement AF 2





# Payload Verification Testing

---

# GrAVE Deployment

- Evaluated the ability of GrAVE to release the retaining latch
- Evaluates pusher mechanisms ability to drive top plate outwards.
- GrAVE was able to release the U-bolt from the latch and drive the plate forward
- Status: Verified

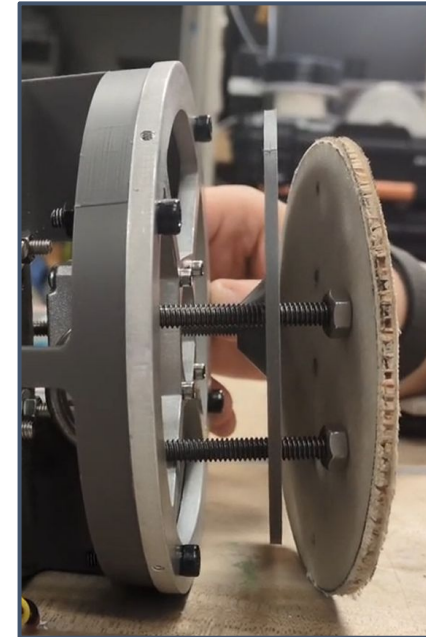



# ZOMBIE Drilling

- Check rack and pinion auger actuation
- Check planetary motor rotation strength while digging through dirt
- Soil collection measured
- 75ml of soil was present after operation.
- Auger was able to drill into the dirt with little difficulty
- Status: Verified

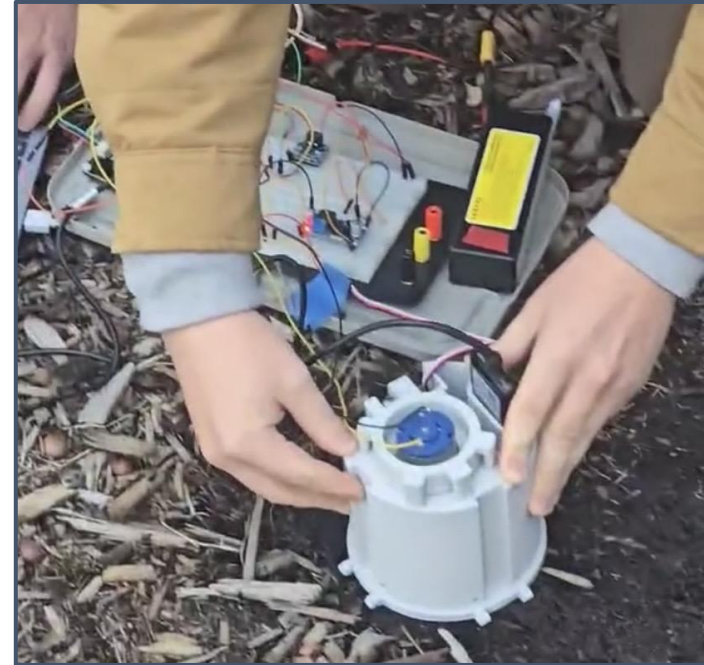



# ZOMBIE Self-righting

- Test leg mechanism to ensure motor has proper strength to deploy legs and self-right
- Linkages warped during deployment
- Collar binding due to uneven resistance
- Motor stalling when close to horizontal
- Status: In progress





# Full System Test

- Run mock script to simulate real flight
- Verifies GrAVE latch release and pusher plate deployment
- Checks ZOMBIE self-righting capabilities
- Checks ZOMBIE drilling capabilities
- Comprehensive test of entire payload series of operations
- Status: Not Verified

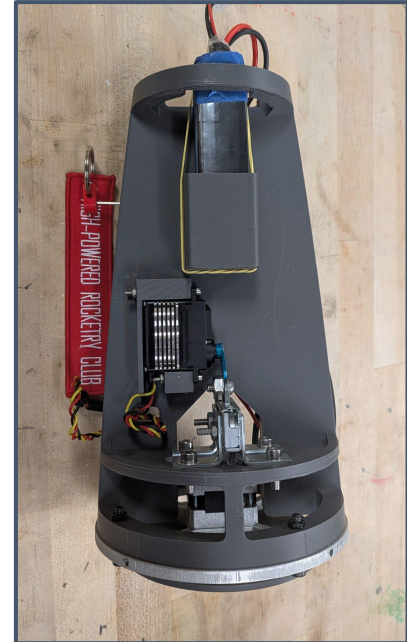



# Payload Demonstration Flight

---

- Focus on GrAVE retention/deployment
- ZOMBIE deployment as secondary objective
- Status: Not Verified





# Requirements Verification

---



# Launch Vehicle and Recovery Requirements

---

- 35 NASA requirements and all 24 team-derived requirements have been verified for the Vehicle
- 18 NASA requirements and all 25 team-derived requirements have been verified for the Recovery system

Test Name	Date Completed	Requirement/Hazard	Verification
Subscale Ejection Test	Oct 20th, 2025	RS 3, DHZ 12,13,14,31,32	Verified
Altimeter Test	Jan 23rd, 2026	DHZ 28, 36	Verified
GPS Test	Jan 23rd, 2026	NASA 3.12, RF 3	Verified
Parachute Drop Test	Feb 2nd, 2026	RF 7 DHZ 33,34	Verified
Fullscale Ejection Test	Feb 12th, 2026	RS 3, DHZ 12,13,14,31,32	Verified
AV Bay Tensile Test	Feb 8th, 2026	LVD 3, DHZ 11, 65	Verified
Fincan Drop Test	Feb 10th, 2026	LVD 1, LVE 4, DHZ 8	Verified
Three Point Bend Test	Jan 30th, 2026	DHZ 6,7	Verified
Fullscale Dry Run	Feb 12th, 2026	RF 5, DHZ 13,14,56,60,62,66,69,75	Verified
MOI Test	Feb 20th, 2026	~	Verified



# Payload Requirements

- Our Air Brakes system has currently verified 10 of the 11 team-derived requirements.
- The Competition Payload has verified 5 of the 11 NASA Requirements, and has Verified 1 of the 14 Team derived Requirements

Test Name	Date Completed	Requirement/Hazard	Verification
ZOMBIE Self-Righting Test	Mar 11th, 2026	PF 3, PE 2, DHZ 40	Not Verified
ZOMBIE Drilling Test	Jan 30th, 2026	PD 5, PE 1	Verified
GrAVE Deployment Test	Feb 7th, 2026	PF 2, PD 3, DHZ 45,46,48,56,59	Not Verified
Ground Simulation of Payload Hardware	Feb 14th, 2026	PF 2, PF 3, PD 3, PD 4, PD 5	Not Verified
Air Brakes Deployment Test	Feb 16th, 2026	AD 1,3, DHZ 19,20,66	Not Verified
Air Brakes Effectiveness Flight Test (VDF)	Feb 24th, 2026	AD 1,4, DHZ 21,22	Verified



# Ground Systems

---



# GPS Receiver

- SteadyBlue Ground Station receives GPS data from the Fluctus during flight and after landing
- Live GPS, number of satellites in view, altitude, velocity, etc. available in Fluctus Control Center
- 905.5 MHz

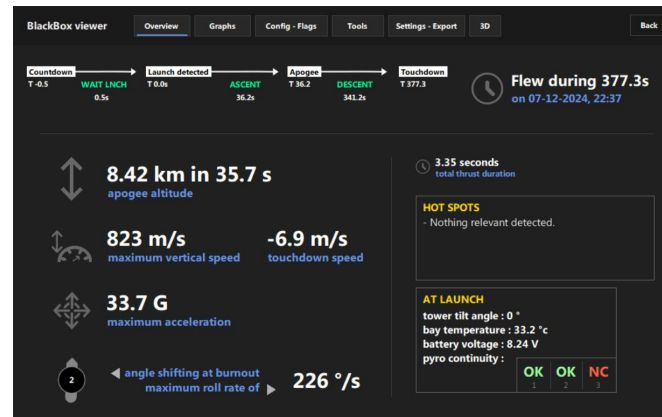
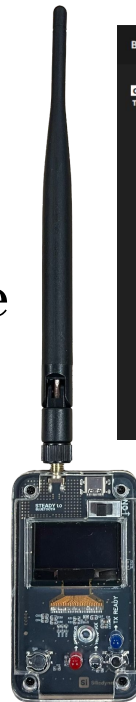



# Questions?

---